

**Direct Drive
Technology**

SKA DDL
IRON CORE
LINEAR MOTORS

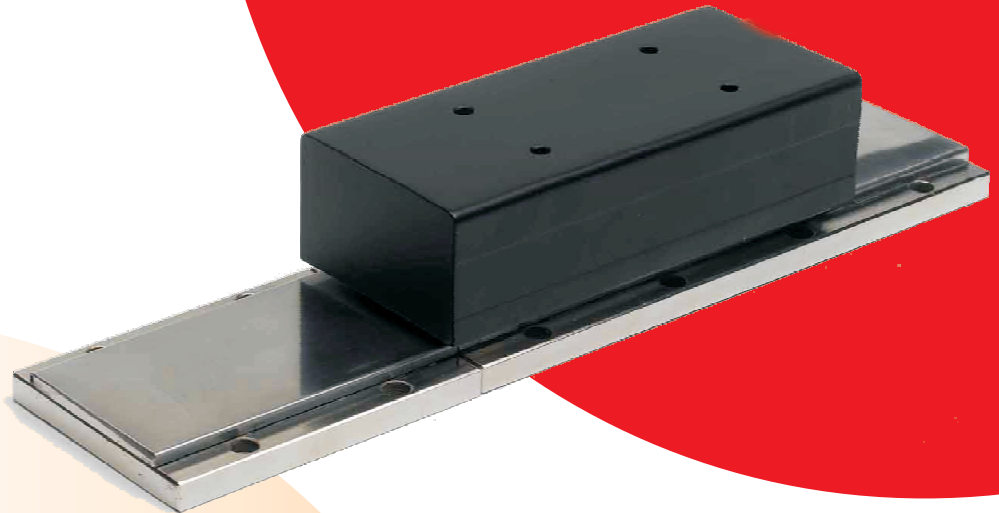

SKA DDL LINEAR MOTOR

Precision, dynamics, performance for the cutting-edge technology in motion control: this is the core prerogative of the direct drive series by Motor Power Company. Our linear and torque motors, available in different modular solutions, respond to the most challenging applications and to your machine integration needs.

The SKA direct drive linear motors are synchronous linear permanent magnet motors created with "iron core" technology. The version proposed by Motor Power Company: the **Frameless** version -includes the moving coil, with embedded temperature sensor and magnetic track-.

- 40N to 2400N continuous force (134.8N to 7200N peak force)
- 5 m/s speed
- 5g (50m/s²) acceleration
- Feedback options: optical or magnetic Sin Cos, TTL and absolute encoder, Hall Sensor.

All SKA motors feature advantages of Direct Drive technology:

replacing all transmission mechanical components (like gearboxes, screws, belts, pulleys, racks) bypass the limits given by backlash, friction and inertia enhance manufactured throughput and reliability improve motion linearity and precision decrease noise levels distribute power and motion control intelligence in the machine simplify and accelerate the design and assembly of the machine save energy in machine operation reduce costs.

	SKA DDL	30.40	30.80	50.75	50.150	55.275	55.550	75.660	75.990	100.1200	100.1600	125.2000	150.2400
Peak force	(N)	134.8	269.5	247	495	825	1650	1980	2970	3600	4800	6000	7200
Continuous force	(N)	40	80	75	150	275	550	660	990	1200	1600	2000	2400
Magnetic attraction	(N)	260	520	430	860	1202	2405	3143	4663	5831	7774	9829	11790
Speed	(m/s)	5	5	5	5	5	5	5	5	5	5	3	3
Acceleration	(m/s ²)	50	50	50	50	50	50	50	50	50	50	50	50
Coil lenght	(mm)	102	186	102	186	186	354	354	522	522	690	690	690
Coil width	(mm)	56	56	76	76	80	80	100	100	125	125	150	175
Coil height	(mm)	23	23	23	23	47.5	47.5	47.5	47.5	47.5	47.5	47.5	47.5
Coil weight	(Kg)	0.55	1	0.8	1.6	3	7	10	14	18	25	31	38
Magnet track width	(mm)	50	50	70	70	90	90	120	120	140	140	175	200
Magnet track height	(mm)	10.8	10.8	10.8	10.8	14.8	14.8	14.8	14.8	14.8	14.8	14.8	14.8
Magnet track weight	(Kg/m)	3.3	3.3	5	5	9.1	9.1	12.2	12.2	14.6	14.6	18	21.4

Data are rated at ΔT = 80°C , 0-40°C environmental temperature - Class F insulation. Performances are rated with natural ventilation

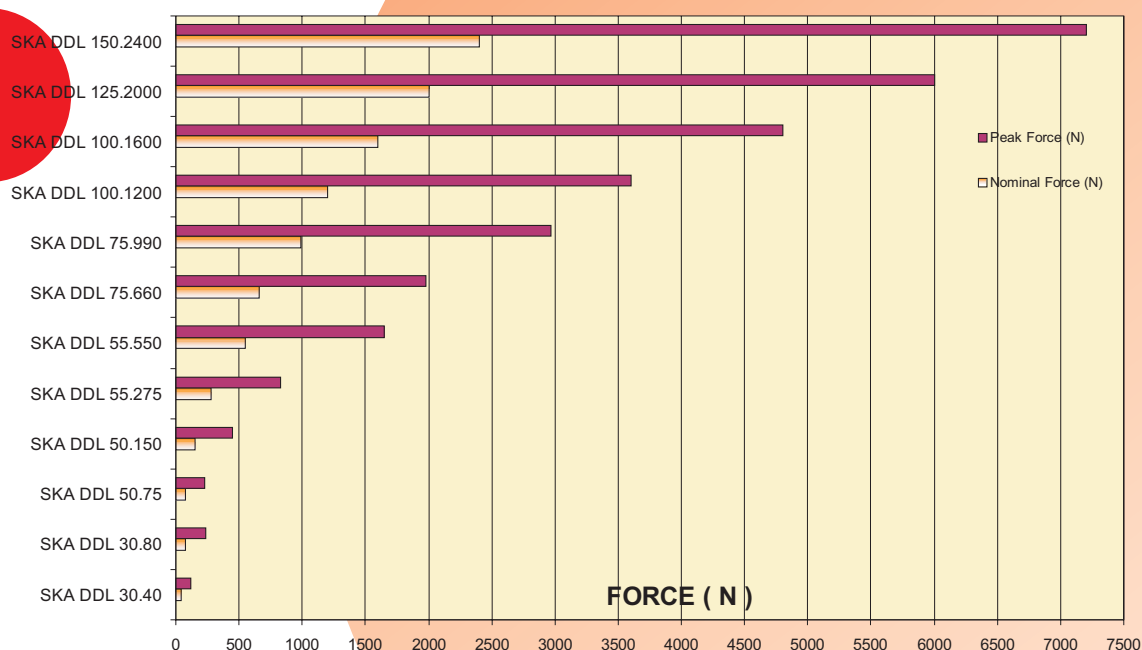

How to order SKA DDL *FRAMELESS VERSION*

SKA DDL	MC	XX	30.80	15	XXX	01	03	XXX
Series name	Motor version	Internal code	Type.Force	Winding	Internal code	Hall Sensors	Connections	Internal code
	MC= Moving Coil	Internal use only	<ul style="list-style-type: none"> — 30.40 — 30.80 — 50.75 — 50.150 — 55.275 — 55.550 — 75.660 — 75.990 — 100.1200 — 100.1600 — 125.2000 — 150.2400 	Consult data sheet	Internal use only	<ul style="list-style-type: none"> 00 Without Hall Sensor 01 With Hall Sensor, 500 mm cable included 	03 500 mm free cable	Internal use only

SKA DDL	MT	XX	30	120	XX
Series name	Motor version	Internal code	Type	Length	Internal code
	MT= Magnet Track	Internal use only	<ul style="list-style-type: none"> — 30 — 50 — 55 — 75 — 100 — 125 — 150 	<ul style="list-style-type: none"> — 120 — 240 — 480* <small>not available for type 30 and 50</small> 	Internal use only



- ① Moving coil
- ② Magnet track
- ③ Embedded Hall Sensor Slot

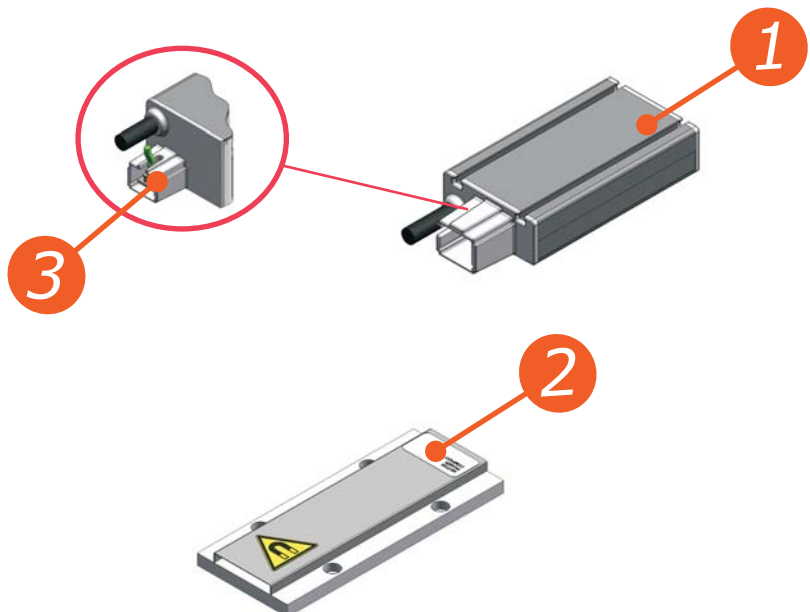

SERIES

SKA DDL

TRANSDUCER SERIES PAGE 1

TRANSDUCERS

TTL OPTICAL ENCODER P200 μ m (FEEDBACK ORDER NR. 008 - 019 - 028)

RATED VOLTAGE	Vn	[Vdc]	5 \pm 5%
RATED CURRENT	In	[mA]	120
MAX OUTPUT FREQUENCY	F	[MHz]	5
WORKING TEMPERATURE	Tn	[°C]	0° \div + 50°
ELECTRONIC TYPE			LINE DRIVER AM 26 LS32
ZERO PULSE			STANDARD
RESOLUTION	R	[μ m]	1 - 5 - 10
ACCURACY	A	[μ m]	\pm 30 μ m/m
OPTICAL LINE PITCH	P	[μ m]	200
MAX SPEED	S	[m/s]	It depends of resolution

SIN COS OPTICAL ENCODER P200 μ m (FEEDBACK ORDER NR. 021)

RATED VOLTAGE	Vn	[Vdc]	5 \pm 5%
RATED CURRENT	In	[mA]	120
MAX OUTPUT FREQUENCY	F	[kHz]	50
WORKING TEMPERATURE	Tn	[°C]	0° \div + 50°
SIGNAL TYPE		[Vdc]	1 Vpp
ZERO PULSE			STANDARD
RESOLUTION	R	[μ m]	Function of the interpolator
ACCURACY	A	[μ m]	\pm 30 μ m/m
OPTICAL LINE PITCH	P	[μ m]	200
MAX SPEED	S	[m/s]	It depends of interpolator

TTL OPTICAL ENCODER P40 μ m (FEEDBACK ORDER NR. 026 - 027)

RATED VOLTAGE	Vn	[Vdc]	5 \pm 5%
RATED CURRENT	In	[mA]	120
MAX OUTPUT FREQUENCY	F	[MHz]	5
WORKING TEMPERATURE	Tn	[°C]	0° \div + 50°
ELECTRONIC TYPE			LINE DRIVER AM 26 LS32
ZERO PULSE			STANDARD
RESOLUTION	R	[μ m]	1 - 2
ACCURACY	A	[μ m]	\pm 5 μ m/m
OPTICAL LINE PITCH	P	[μ m]	40
MAX SPEED	S	[m/s]	It depends of resolution

SIN COS OPTICAL ENCODER P40 μ m (FEEDBACK ORDER NR. 015)

RATED VOLTAGE	Vn	[Vdc]	5 \pm 5%
RATED CURRENT	In	[mA]	120
MAX OUTPUT FREQUENCY	F	[kHz]	250
WORKING TEMPERATURE	Tn	[°C]	0° \div + 50°
SIGNAL TYPE		[Vdc]	1 Vpp
ZERO PULSE			STANDARD
RESOLUTION	R	[μ m]	Function of the interpolator
ACCURACY	A	[μ m]	\pm 5 μ m/m
OPTICAL LINE PITCH	P	[μ m]	40
MAX SPEED	S	[m/s]	It depends of interpolator

SERIES

SKA DDL

TRANSDUCER SERIES PAGE 2

TRANSDUCERS

TTL MAGNETIC ENCODER P2mm (FEEDBACK ORDER NR. 006 - 007 - 024)			
RATED VOLTAGE	Vn	[Vdc]	5 ± 2.5%
RATED CURRENT	In	[mA]	200
MAX OUTPUT FREQUENCY	F	[kHz]	500
WORKING TEMPERATURE	Tn	[°C]	0° ÷ + 50°
ELECTRONIC TYPE			LINE DRIVER AM 26 LS32
ZERO PULSE			STANDARD
RESOLUTION	R	[μm]	1 - 2 - 10
ACCURACY	A	[mm]	± [0.025+(0.02*L)] (L : stroke length in mt)
MAGNETIC TAPE PITCH	P	[mm]	2
MAX SPEED	S	[m/s]	It depends of resolution
TTL MAGNETIC ENCODER P1mm (FEEDBACK ORDER NR. 031 - 032 - 033 - 034)			
RATED VOLTAGE	Vn	[Vdc]	5 ± 5%
RATED CURRENT	In	[mA]	25
MAX OUTPUT FREQUENCY	F	[kHz]	500
WORKING TEMPERATURE	Tn	[°C]	-10° ÷ + 70°
ELECTRONIC TYPE			LINE DRIVER AM 26 LS32
ZERO PULSE			STANDARD
RESOLUTION	R	[μm]	0.2 - 1 - 2 - 5
ACCURACY	A	[μm]	± 10 μm/m
MAGNETIC TAPE PITCH	P	[mm]	1
MAX SPEED	S	[m/s]	It depends of resolution
SIN COS MAGNETIC ENCODER P1mm (FEEDBACK ORDER NR. 030)			
RATED VOLTAGE	Vn	[Vdc]	5 ± 5%
RATED CURRENT	In	[mA]	50
MAX OUTPUT FREQUENCY	F	[kHz]	20
WORKING TEMPERATURE	Tn	[°C]	-10° ÷ + 70°
SIGNAL TYPE		[Vdc]	1 Vpp
ZERO PULSE			STANDARD
RESOLUTION	R	[μm]	Function of the interpolator
ACCURACY	A	[μm]	± 10 μm/m
MAGNETIC TAPE PITCH	P	[mm]	1
MAX SPEED	S	[m/s]	It depends of interpolator
HALL SENSOR			
RATED VOLTAGE	Vn	[Vdc]	5
RATED CURRENT	In	[mA]	100
WORKING TEMPERATURE	Tn	[°C]	-20° ÷ +100°
N° OF COMMUTATION SIGNALS			3 Common Mode 5v

SERIES

SKA DDL

HALL SENSOR

COMMUTATION SENSOR SEQUENCE

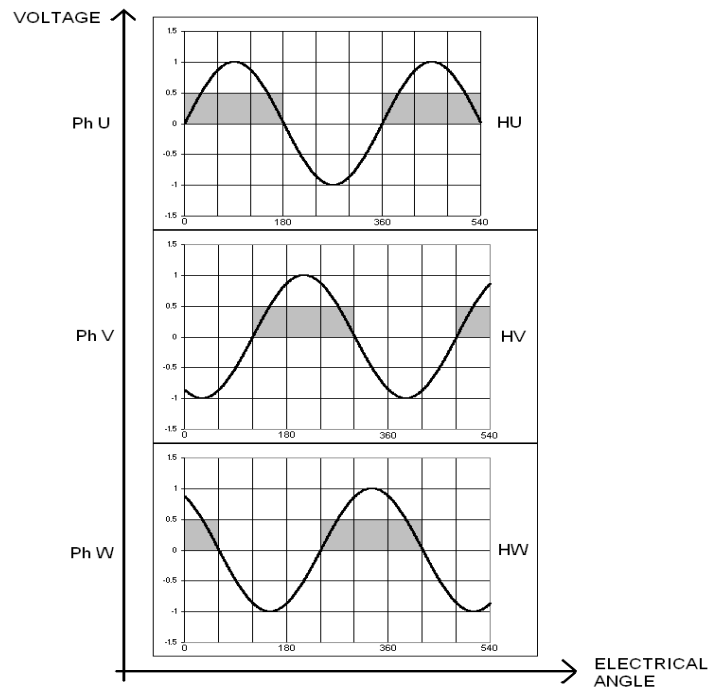
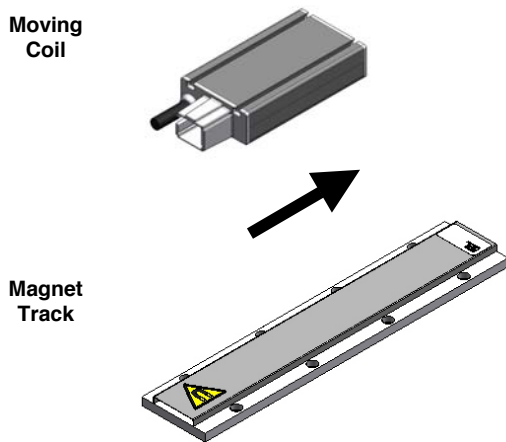

MOVING COIL WIRING			
Coil		Hall Sensor	
Power Cable	Wire Color	Signal Cable	Wire Color
U	Gray	HU	Gray
V	Black	HV	Green
W	Brown	HW	Pink
PE	Yellow/Green	0Vdc	White
Shield	Shield wire	+5Vdc	Brown

When the moving coil translates in the direction indicated by the arrow, the hall sensor output relationship with the power phases as shown in the figures above.

SERIES

SKA DDL 30.40 – 30.80

FORCE [N]

40/80

SINEWAVE FORM		SYMBOL	UNITS	TYPE OF WINDING XX = preferential winding			
				12	14	15	16
MOTOR SPEED	Vn drive 145 V (ac) 3phase		[m/s]	4.5	3	2	1.5
	Vn drive 230 V (ac) 3phase		[m/s]		4.5	3	2
	Vn drive 400 V (ac) 3phase		[m/s]			5	4
COMMON RATINGS							
	Voltage constant ± 5%	Ke	[Vrms/m/s]	24	36	55	72
	Pole pitch	P	[mm]	12			
	Temperature range	Tr	[°C]	0 ÷ 40°			
SKA DDL 30.40							
MOTOR RATINGS	Continuous force(0 m/s)	F _{n0}	[N]	40			
	Peak force	F _{max}	[N]	134.8			
	Force constant ± 5%	K _f	[N/Arms]	40	60	91	
	Rated current (0 m/s)	I _{n0}	[Arms]	1	0.67	0.44	
	Peak current	I _{fmax}	[Arms]	4	2.7	1.76	
	Phase/phase res. ± 5% a 20°C	R _{ff}	[Ohm]	12	26	58	
	Phase/phase inductance	L _{ff}	[mH]	35	78	180	
	Electrical time constant	T _e	[msec]	3.0			
	Attraction force	F _m	[N]	260			
	Power loss	P _d	[W]	26			
	Thermal resistance	R _{th}	[°C/W]	3.5			
	Motor constant	K _m	[N/√W]	7.84			
SKA DDL 30.80							
	Continuous force(0 m/s)	F _{n0}	[N]	80			
	Peak force	F _{max}	[N]	269.6			
	Force constant ± 5%	K _f	[N/Arms]	40	60	91	121
	Rated current (0 m/s)	I _{n0}	[Arms]	2	1.33	0.88	0.66
	Peak current	I _{fmax}	[Arms]	8	5.33	3.51	2.64
	Phase/phase res. ± 5% a 20°C	R _{ff}	[Ohm]	6.0	13	29	52
	Phase/phase inductance	L _{ff}	[mH]	18	39	90	156
	Electrical time constant	T _e	[msec]	3.0			
	Attraction force	F _m	[N]	520			
	Power loss	P _d	[W]	52			
	Thermal resistance	R _{th}	[°C/W]	1.75			
	Motor constant	K _m	[N/√W]	11.1			
THERMAL PROTECTION	Type of thermal cut-off				N C : normally closed		
	Rated voltage	V _n	[Vac]	250			
	Rated current	I _n	[A]	2.5			
	Operative temperature	T _n	[°C]	130 °C ± 5%			
	Resetting temperature	Tr	[°C]	100 °C ± 15°C			
	Operative time		[ms]	1			
	Insulation class			F			

Datasheet n°: SKADDL-2012-04-17

SERIES

SKA

DDL 30

FORCE [N]

40/80

MOTOR DIMENSIONS

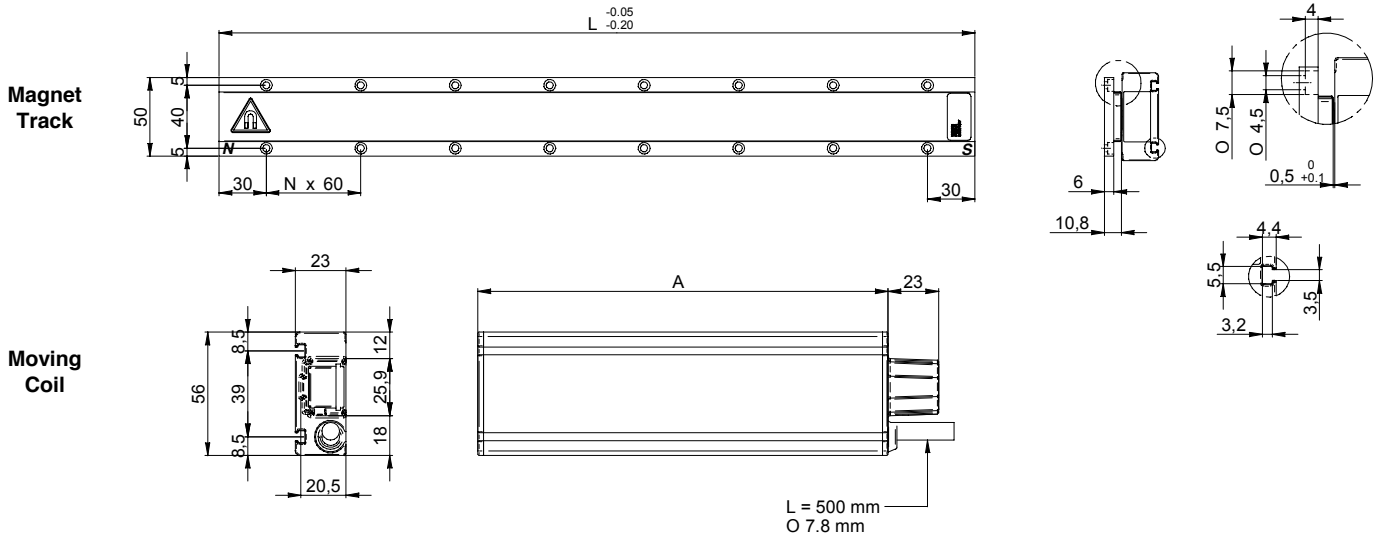

Magnet Track		Moving Coil	
Type	L (mm)	Type	A (mm)
30-120	120	30.40	102
30-240	240	30.80	186

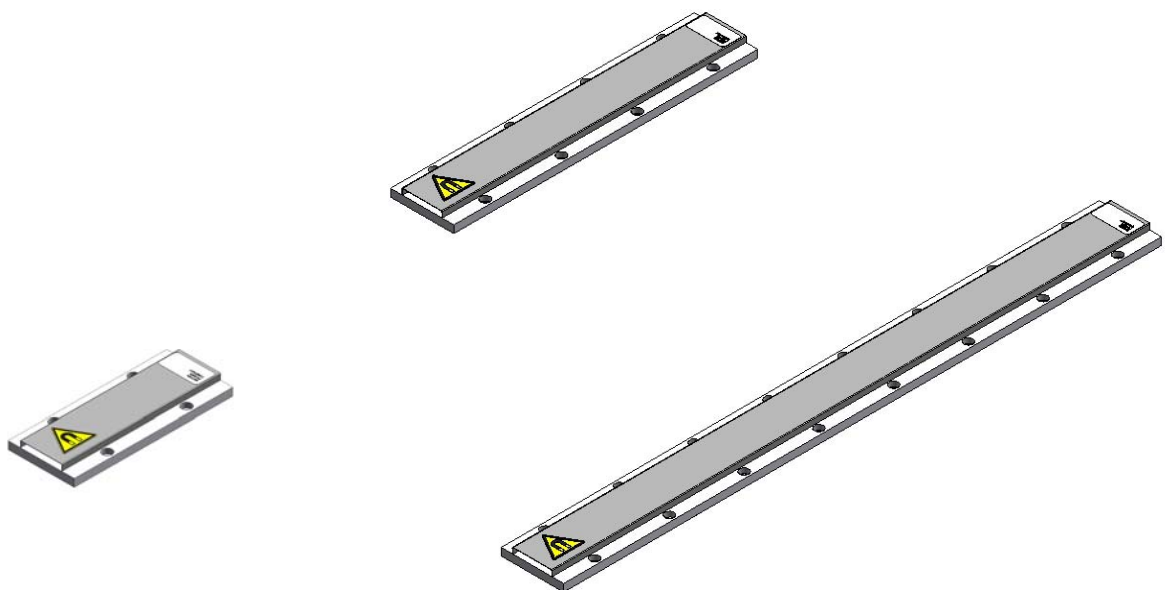
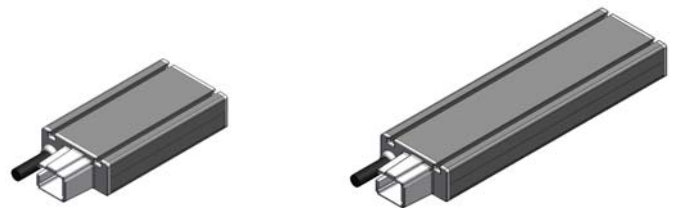

SERIES

FORCE [N]

SKA DDL 50.75 – 50.150

75/150

SINEWAVE FORM		SYMBOL	UNITS	TYPE OF WINDING XX = preferential winding			
				12	15	16	17
MOTOR SPEED	Vn drive 145 V (ac) 3phase		[m/s]	4.5	2	1.5	1.1
	Vn drive 230 V (ac) 3phase		[m/s]		3	2	1.5
	Vn drive 400 V (ac) 3phase		[m/s]		5	4	3
COMMON RATINGS							
	Voltage constant ± 5%	Ke	[Vrms/m/s]	24	55	72	97
	Pole pitch	P	[mm]		12		
	Temperature range	Tr	[°C]		0 ÷ 40°		
SKA DDL 50.75							
MOTOR RATINGS	Continuous force(0 m/s)	Fn0	[N]		75		
	Peak force	Fmax	[N]		247		
	Force constant ± 5%	Kf	[N/Arms]	40	91	121	
	Rated current (0 m/s)	In0	[Arms]	1.88	0.82	0.62	
	Peak current	I fmax	[Arms]	7.5	3.28	2.48	
	Phase/phase res. ± 5% a 20°C	Rff	[Ohm]	6.0	32	55	
	Phase/phase inductance	Lff	[mH]	21	111	190	
	Electrical time constant	Te	[msec]		3.5		
	Attraction force	Fm	[N]		430		
	Power loss	Pd	[W]		45		
	Thermal resistance	Rth	[°C/W]		2.0		
	Motor constant	Km	[N/√W]		11.2		
	SKA DDL 50.150						
	Continuous force(0 m/s)	Fn0	[N]		150		
	Peak force	Fmax	[N]		495		
	Force constant ± 5%	Kf	[N/Arms]	40	91	161	
	Rated current (0 m/s)	In0	[Arms]	3.76	1.64	0.93	
	Peak current	I fmax	[Arms]	15	6.56	3.72	
	Phase/phase res. ± 5% a 20°C	Rff	[Ohm]	3.0	16	49	
	Phase/phase inductance	Lff	[mH]	11	55	172	
	Electrical time constant	Te	[msec]		3.5		
	Attraction force	Fm	[N]		860		
	Power loss	Pd	[W]		90		
	Thermal resistance	Rth	[°C/W]		1.0		
	Motor constant	Km	[N/√W]		15.8		
THERMAL PROTECTION	Type of thermal cut-off				N C : normally closed		
	Rated voltage	Vn	[Vac]		250		
	Rated current	In	[A]		2.5		
	Operative temperature	Tn	[°C]		130 °C ± 5%		
	Resetting temperature	Tr	[°C]		100 °C ± 15°C		
	Operative time		[ms]		1		
	Insulation class				F		

Datasheet n°: SKADDL-2012-04-17

SERIES

SKA

DDL 50

FORCE [N]

75/150

MOTOR DIMENSIONS

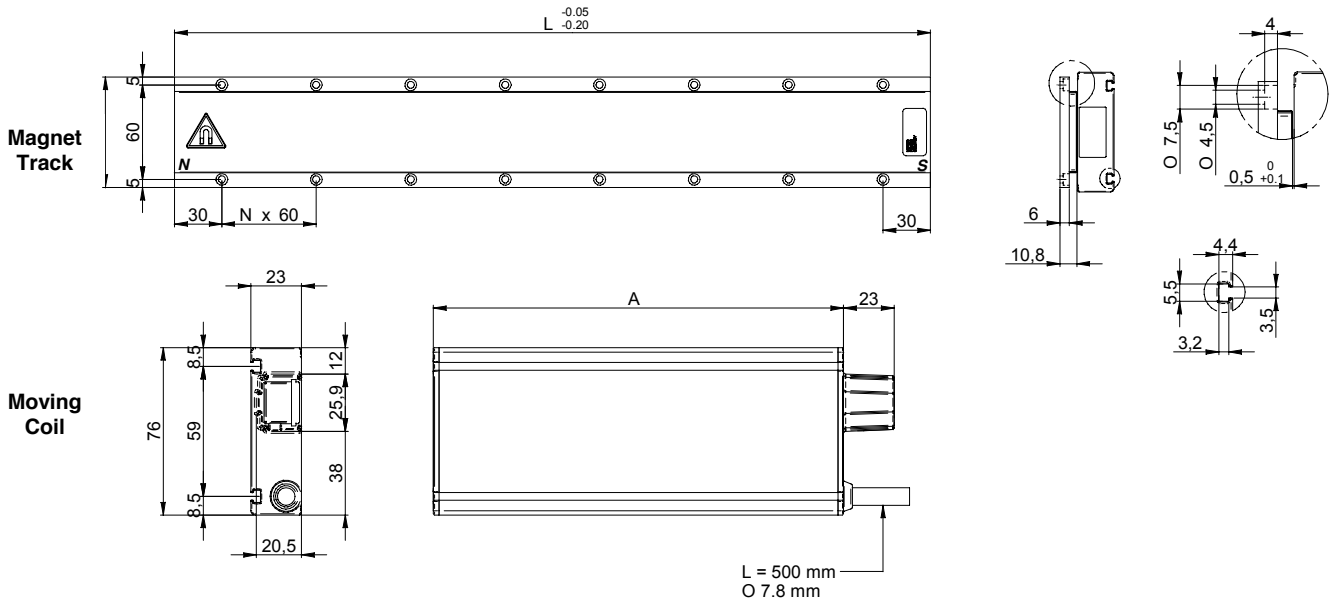

Magnet Track		Moving Coil	
Type	L (mm)	Type	A (mm)
50-120	120	50.75	102
50-240	240	50.150	186

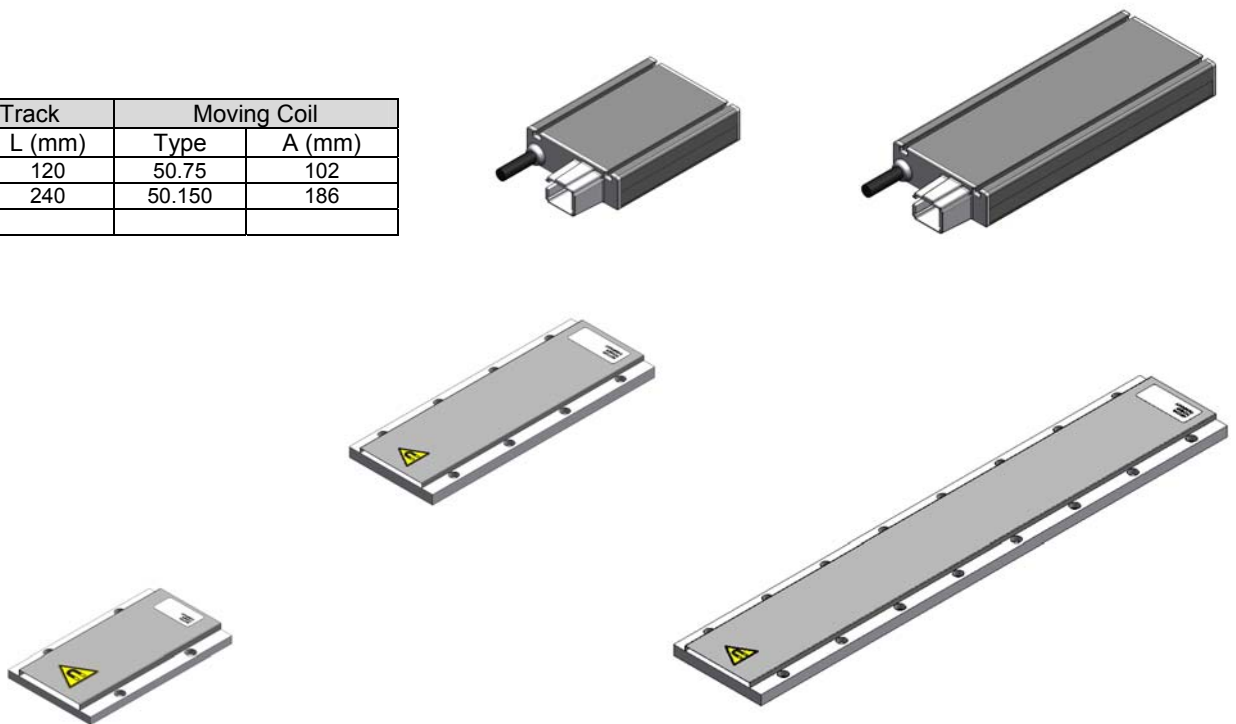

Datasheet n°: SKADDL-2008-03-00

SERIES

SKA DDL 55.275 – 55.550

FORCE [N]

275/550

SINEWAVE FORM		SYMBOL	UNITS	TYPE OF WINDING XX = preferential winding				
				14	15	16	17	31
MOTOR SPEED	Vn drive 145 V (ac) 3phase		[m/s]	3	2	1.5	1.1	
	Vn drive 230 V (ac) 3phase		[m/s]	4.5	3	2	1.5	1
	Vn drive 400 V (ac) 3phase		[m/s]		5	4	3	2
COMMON RATINGS								
	Voltage constant ± 5%	Ke	[Vrms/m/s]	36	55	72	97	116
	Pole pitch	P	[mm]			24		
	Temperature range	Tr	[°C]			0 ÷ 40°		
SKA DDL 55.275								
MOTOR RATINGS	Continuous force(0 m/s)	Fn0	[N]			275		
	Peak force	Fmax	[N]			825		
	Force constant ± 5%	Kf	[N/Arms]	60	91	121	161	192
	Rated current (0 m/s)	In0	[Arms]	4.6	3.0	2.28	1.71	1.43
	Peak current	I fmax	[Arms]	18.38	12.0	9.13	6.84	5.7
	Phase/phase res. ± 5% a 20°C	Rff	[Ohm]	2.3	4.9	8.8	15.0	23
	Phase/phase inductance	Lff	[mH]	32	68	120	206	325
	Electrical time constant	Te	[msec]			13.8		
	Attraction force	Fm	[N]			1202		
	Power loss	Pd	[W]			96		
	Thermal resistance	Rth	[°C/W]			0.94		
	Motor constant	Km	[N/√W]			28.1		
SKA DDL 55. 550								
	Continuous force(0 m/s)	Fn0	[N]			550		
	Peak force	Fmax	[N]			1650		
	Force constant ± 5%	Kf	[N/Arms]		86	113	151	192
	Rated current (0 m/s)	In0	[Arms]		6.41	4.87	3.65	2.86
	Peak current	I fmax	[Arms]		25.65	19.47	14.59	11.4
	Phase/phase res. ± 5% a 20°C	Rff	[Ohm]		2.5	4.4	7.5	12
	Phase/phase inductance	Lff	[mH]		34	60	103	162
	Electrical time constant	Te	[msec]			13.8		
	Attraction force	Fm	[N]			2405		
	Power loss	Pd	[W]			192		
	Thermal resistance	Rth	[°C/W]			0.47		
	Motor constant	Km	[N/√W]			39.7		
THERMAL PROTECTION	Type of thermal cut-off			N C : normally closed				
	Rated voltage	Vn	[Vac]	250				
	Rated current	In	[A]	2.5				
	Operative temperature	Tn	[°C]	130 °C ± 5%				
	Resetting temperature	Tr	[°C]	100 °C ± 15°C				
	Operative time		[ms]	1				
	Insulation class			F				

Datasheet n°: SKADDL-2012-04-17

SERIES

SKA

DDL 55

FORCE [N]

275/550

MOTOR DIMENSIONS

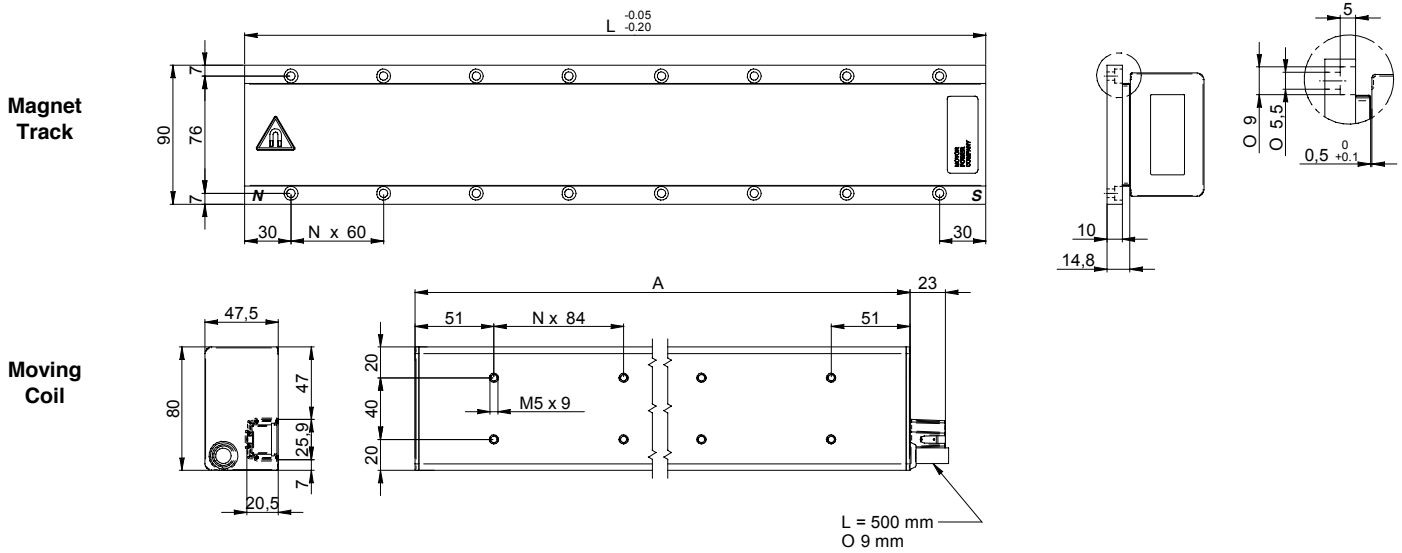

Magnet Track		Moving Coil	
Type	L (mm)	Type	A (mm)
55-120	120	55.275	186
55-240	240	55.550	354
55-480	480		

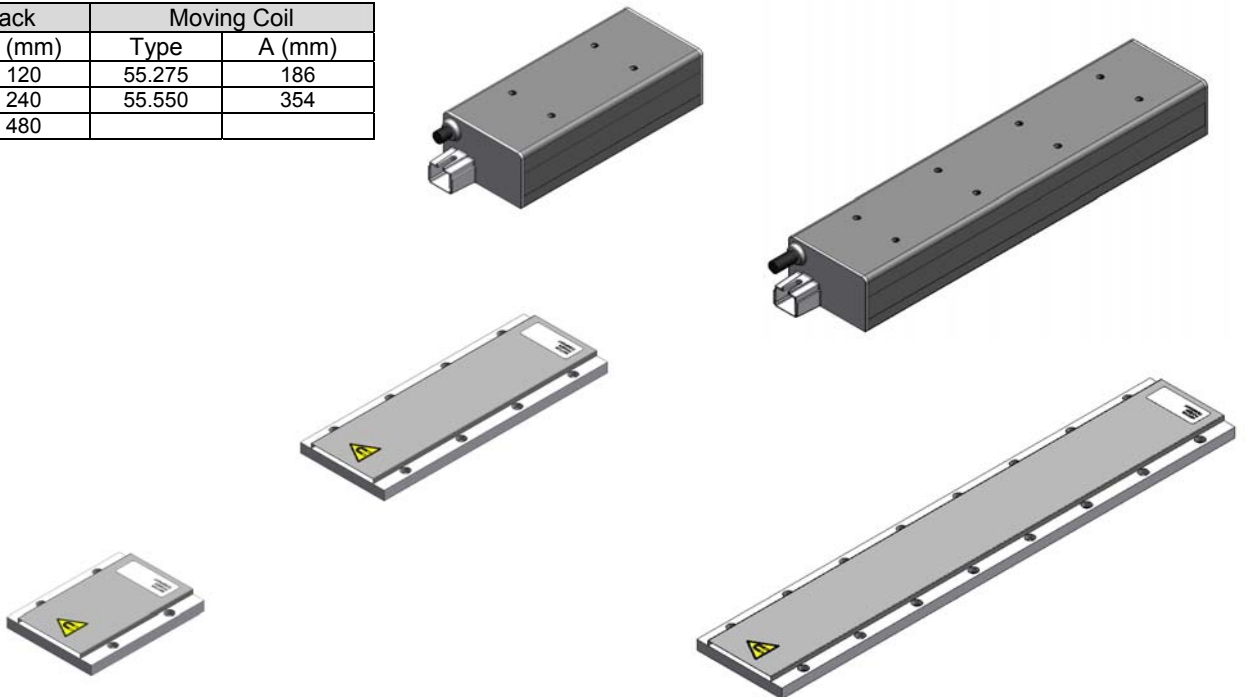

Datasheet n°: SKADDL-2008-03-00

SERIES

SKA DDL 75.660 – 75.990

FORCE [N]

660/990

SINEWAVE FORM		SYMBOL	UNITS	TYPE OF WINDING XX = preferential winding		
				15	17	
MOTR SPEED	Vn drive 145 V (ac) 3phase		[m/s]	2	1.1	
	Vn drive 230 V (ac) 3phase		[m/s]	3	1.5	
	Vn drive 400 V (ac) 3phase		[m/s]	5	3	
COMMON RATINGS						
	Voltage constant ± 5%	Ke	[Vrms/m/s]	55	97	
	Pole pitch	P	[mm]		24	
	Temperature range	Tr	[°C]	0 ÷ 40°		
SKA DDL 75.660						
MOTOR RATINGS	Continuous force(0 m/s)	Fn0	[N]		660	
	Peak force	Fmax	[N]		1980	
	Force constant ± 5%	Kf	[N/Arms]	86	151	
	Rated current (0 m/s)	In0	[Arms]	7.7	4.38	
	Peak current	I fmax	[Arms]	30.78	17.5	
	Phase/phase res. ± 5% a 20°C	Rff	[Ohm]	2.3	7.5	
	Phase/phase inductance	Lff	[mH]	31	97	
	Electrical time constant	Te	[msec]		13	
	Attraction force	Fm	[N]		3143	
	Power loss	Pd	[W]		290	
	Thermal resistance	Rth	[°C/W]		0.31	
	Motor constant	Km	[N/√W]		39	
	SKA DDL 75.990					
	Continuous force(0 m/s)	Fn0	[N]		990	
	Peak force	Fmax	[N]		2970	
	Force constant ± 5%	Kf	[N/Arms]	86	151	
	Rated current (0 m/s)	In0	[Arms]	11.54	6.57	
	Peak current	I fmax	[Arms]	46.17	26.25	
	Phase/phase res. ± 5% a 20°C	Rff	[Ohm]	1.53	5.0	
	Phase/phase inductance	Lff	[mH]	20	64	
	Electrical time constant	Te	[msec]		13	
	Attraction force	Fm	[N]		4663	
	Power loss	Pd	[W]		435	
	Thermal resistance	Rth	[°C/W]		0.21	
	Motor constant	Km	[N/√W]		47	
THERMAL PROTECTION	Type of thermal cut-off			N C : normally closed		
	Rated voltage	Vn	[Vac]	250		
	Rated current	In	[A]	2.5		
	Operative temperature	Tn	[°C]	130 °C ± 5%		
	Resetting temperature	Tr	[°C]	100 °C ± 15°C		
	Operative time		[ms]	1		
	Insulation class			F		

Datasheet n°: SKADDL- 2012-04-18

SERIES

SKA

DDL 75

FORCE [N]

660/990

MOTOR DIMENSIONS

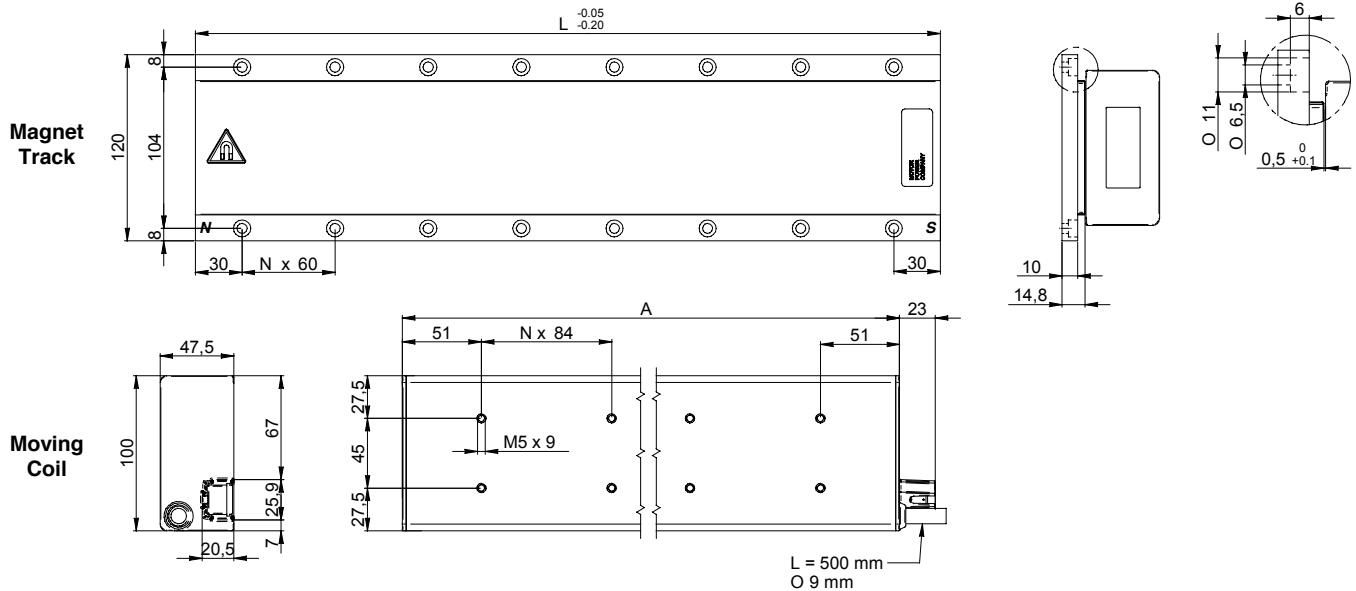

Magnet Track		Moving Coil	
Type	L (mm)	Type	A (mm)
75-120	120	75.660	354
75-240	240	75.990	522
75-480	480		

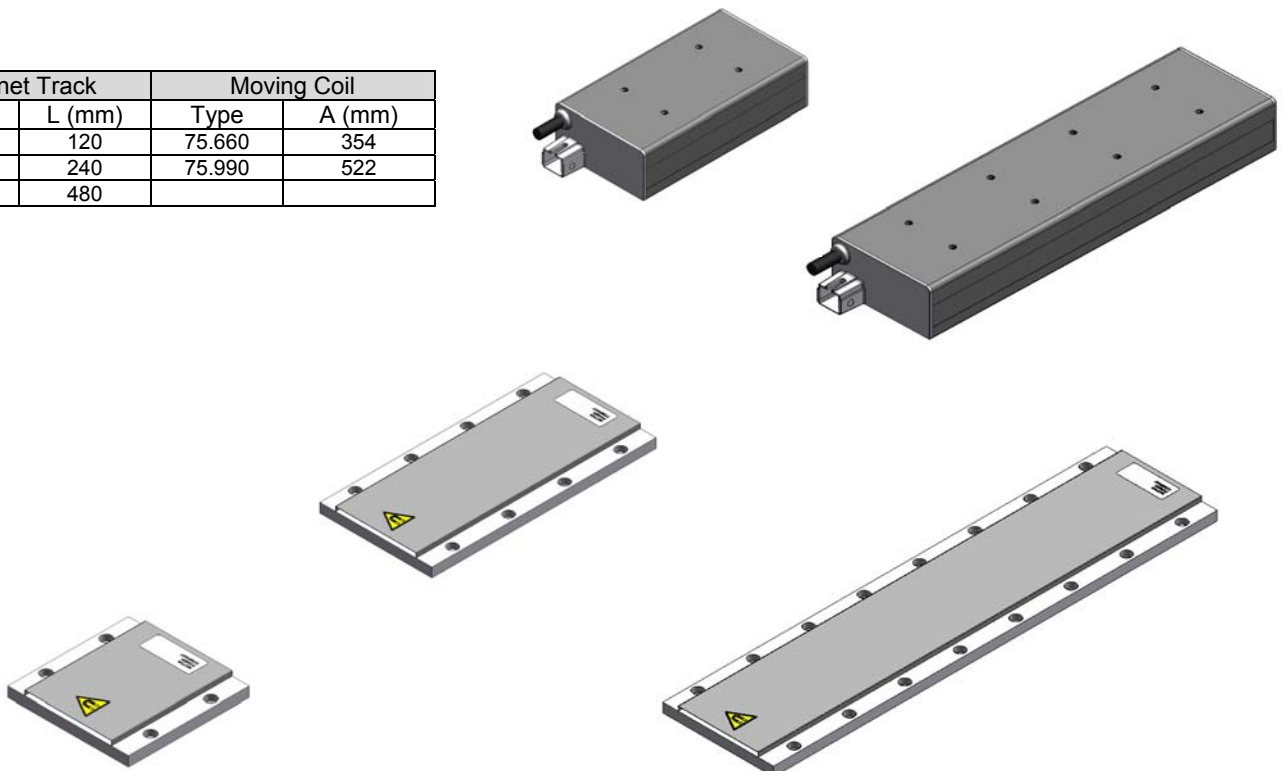

Datasheet n°: SKADDL-2008-03-00

SERIES

SKA DDL 100.1200 – 100.1600

FORCE [N]
1200/1600

SINEWAVE FORM		SYMBOL	UNITS	TYPE OF WINDING XX = preferential winding		
				15	16	17
MOTOR SPEED	Vn drive 145 V (ac) 3phase		[m/s]	2	1.5	1.1
	Vn drive 230 V (ac) 3phase		[m/s]	3	2	1.5
	Vn drive 400 V (ac) 3phase		[m/s]	5	4	3
COMMON RATINGS						
	Voltage constant ± 5%	Ke	[Vrms/m/s]	55	72	97
	Pole pitch	P	[mm]			24
	Temperature range	Tr	[°C]			0 ÷ 40°
SKA DDL 100.1200						
MOTOR RATINGS	Continuous force(0 m/s)	Fn0	[N]			1200
	Peak force	Fmax	[N]			3600
	Force constant ± 5%	Kf	[N/Arms]	86		151
	Rated current (0 m/s)	In0	[Arms]	14		7.96
	Peak current	I fmax	[Arms]	56		31.8
	Phase/phase res. ± 5% a 20°C	Rff	[Ohm]	0.80		2.5
	Phase/phase inductance	Lff	[mH]	15		44
	Electrical time constant	Te	[msec]			18
	Attraction force	Fm	[N]			5831
	Power loss	Pd	[W]			345
	Thermal resistance	Rth	[°C/W]			0.26
Motor constant	Km	[N/√W]			64.6	
SKA DDL 100.1600						
	Continuous force(0 m/s)	Fn0	[N]			1600
	Peak force	Fmax	[N]			4800
	Force constant ± 5%	Kf	[N/Arms]		110	147
	Rated current (0 m/s)	In0	[Arms]		14.5	10.9
	Peak current	I fmax	[Arms]		56.5	42.3
	Phase/phase res. ± 5% a 20°C	Rff	[Ohm]		1.0	1.9
	Phase/phase inductance	Lff	[mH]		18	33
	Electrical time constant	Te	[msec]			18
	Attraction force	Fm	[N]			7774
	Power loss	Pd	[W]			460
	Thermal resistance	Rth	[°C/W]			0.19
	Motor constant	Km	[N/√W]			74.6
THERMAL PROTECTION	Type of thermal cut-off					N C : normally closed
	Rated voltage	Vn	[Vac]			250
	Rated current	In	[A]			2.5
	Operative temperature	Tn	[°C]			130 °C ± 5%
	Resetting temperature	Tr	[°C]			100 °C ± 15°C
	Operative time		[ms]			1
	Insulation class					F

Datasheet n°: SKADDL – 2012-04-18

SERIES

SKA

DDL 100

FORCE [N]

1200/1600

MOTOR DIMENSIONS

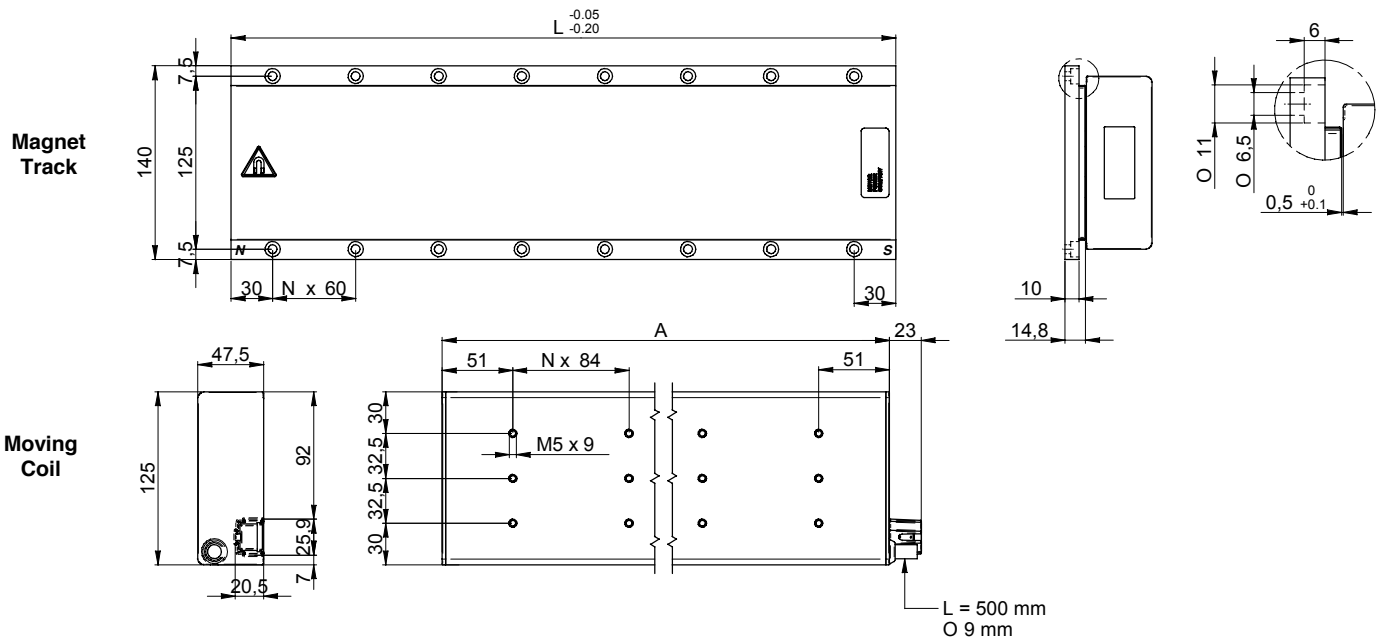

Magnet Track		Moving Coil	
Type	L (mm)	Type	A (mm)
100-120	120	100.1200	522
100-240	240	100.1600	690
100-480	480		

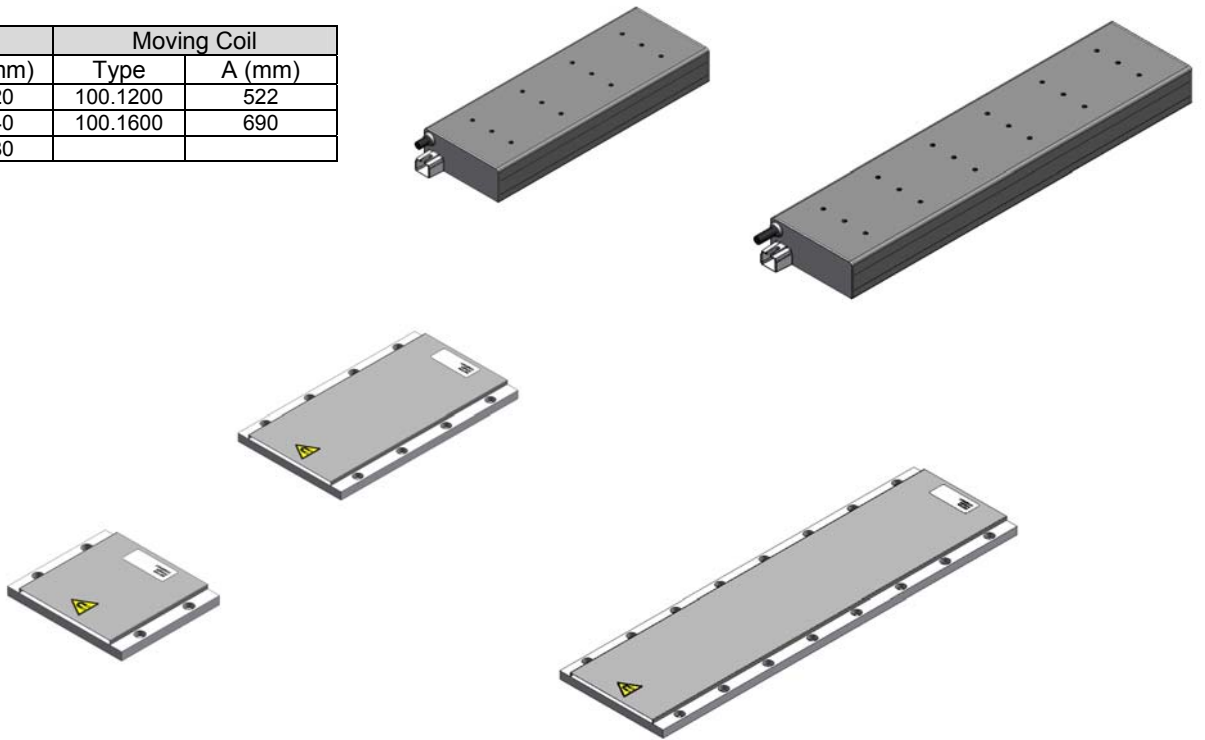

SERIES

SKA

DDL 100

FORCE [N]

1200/1600

MOTOR DIMENSIONS

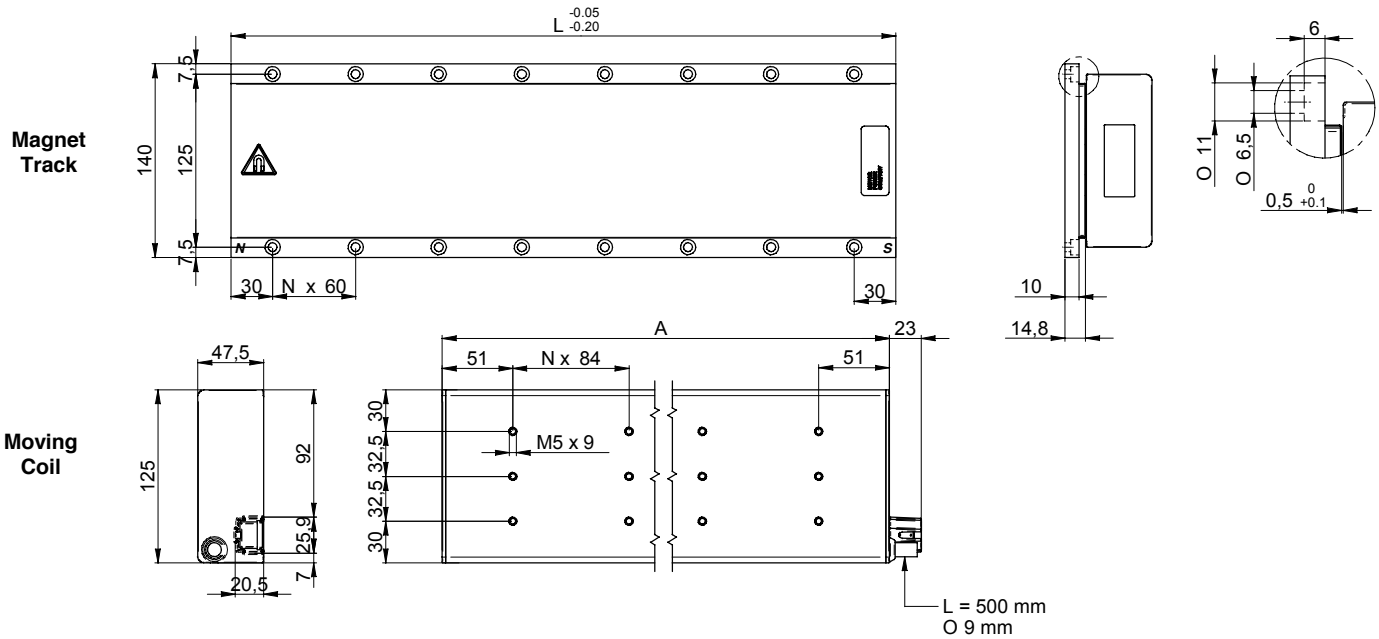

Magnet Track		Moving Coil	
Type	L (mm)	Type	A (mm)
100-120	120	100.1200	522
100-240	240	100.1600	690
100-480	480		

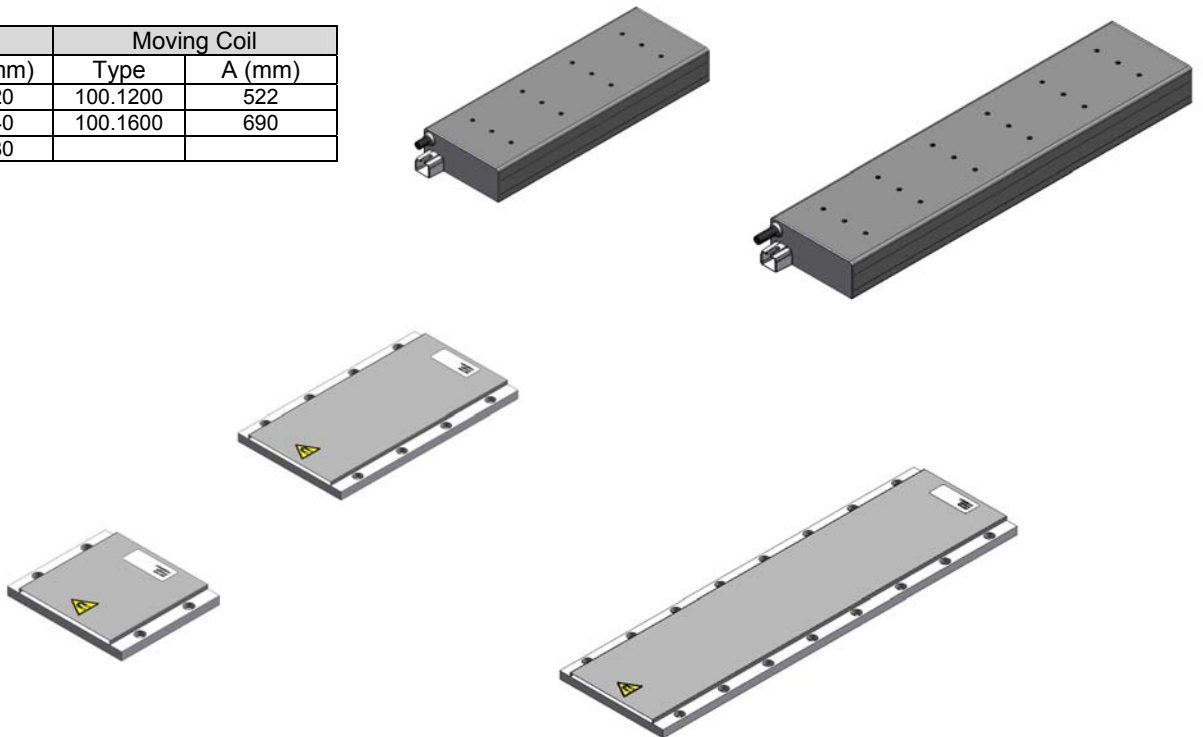

SERIES

SKA DDL 125.2000

FORCE [N]

2000

SINEWAVE FORM		SYMBOL	UNITS	TYPE OF WINDING XX = preferential winding																		
				17																		
MOTR SPEED	Vn drive 145 V (ac) 3phase		[m/s]																			
	Vn drive 230 V (ac) 3phase		[m/s]																			
	Vn drive 400 V (ac) 3phase		[m/s]																			
COMMON RATINGS																						
	Voltage constant ± 5%	Ke	[Vrms/m/s]																			
	Pole pitch	P	[mm]																			
	Temperature range	Tr	[°C]																			
SKA DDL 125.2000																						
MOTOR RATINGS	Continuous force(0 m/s)	Fn0	[N]																			
	Peak force	Fmax	[N]																			
	Force constant ± 5%	Kf	[N/Arms]																			
	Rated current (0 m/s)	In0	[Arms]																			
	Peak current	I fmax	[Arms]																			
	Phase/phase res. ± 5% a 20°C	Rff	[Ohm]																			
	Phase/phase inductance	Lff	[mH]																			
	Electrical time constant	Te	[msec]																			
	Attraction force	Fm	[N]																			
	Power loss	Pd	[W]																			
	Thermal resistance	Rth	[°C/W]																			
	Motor constant	Km	[N/√W]																			
	SKA DDL 125.2000																					
		Continuous force(0 m/s)	Fn0	[N]																		
		Peak force	Fmax	[N]																		
	Force constant ± 5%	Kf	[N/Arms]																			
	Rated current (0 m/s)	In0	[Arms]																			
	Peak current	I fmax	[Arms]																			
	Phase/phase res. ± 5% a 20°C	Rff	[Ohm]																			
	Phase/phase inductance	Lff	[mH]																			
	Electrical time constant	Te	[msec]																			
	Attraction force	Fm	[N]																			
	Power loss	Pd	[W]																			
	Thermal resistance	Rth	[°C/W]																			
	Motor constant	Km	[N/√W]																			
THERMAL PROTECTION	Type of thermal cut-off																					
	Rated voltage	Vn	[Vac]																			
	Rated current	In	[A]																			
	Operative temperature	Tn	[°C]																			
	Resetting temperature	Tr	[°C]																			
	Operative time		[ms]																			
	Insulation class																					

Datasheet n°: SKADDL – 2008-03-00

SERIES

SKA

DDL 125

FORCE [N]

2000

MOTOR DIMENSIONS

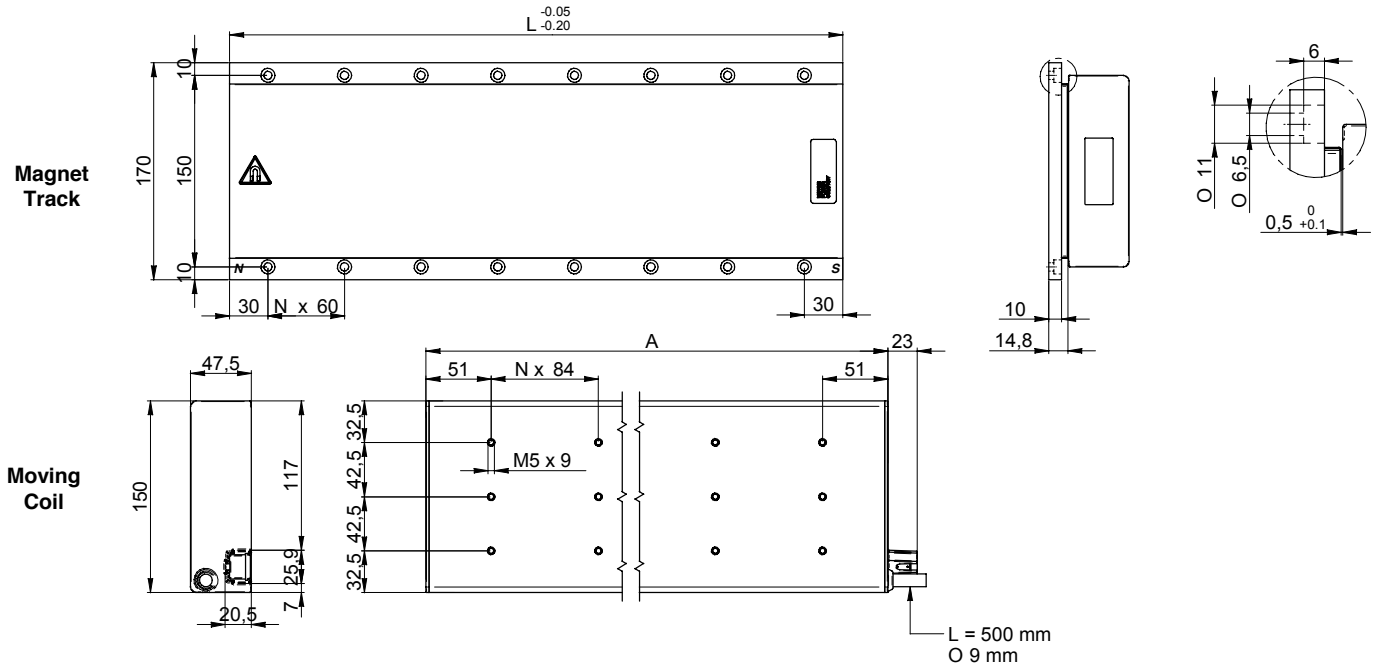

Magnet Track		Moving Coil	
Type	L (mm)	Type	A (mm)
125-120	120	125.2000	690
125-240	240		
125-480	480		

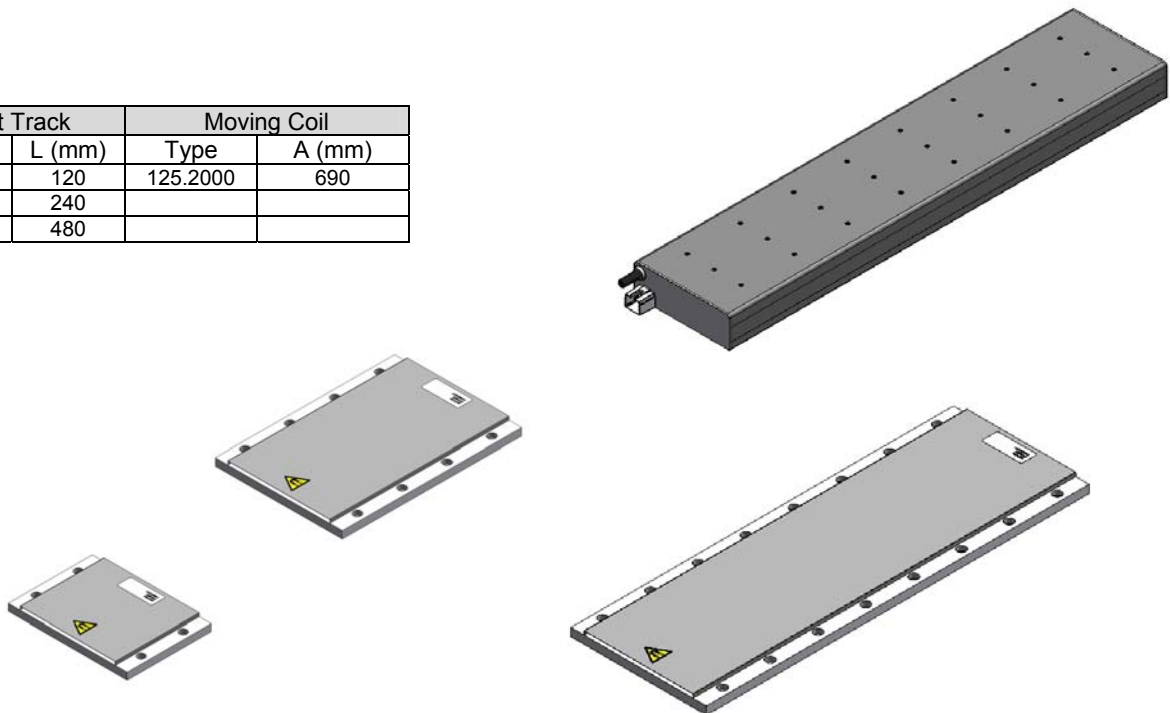

Datasheet n°: SKADDL-2008-03-00

SERIES

FORCE [N]

SKA DDL 150.2400

2400

SINEWAVE FORM		SYMBOL	UNITS	TYPE OF WINDING xx = preferential winding				
MOTOR SPEED	Vn drive 145 V (ac) 3phase		[m/s]		17			
	Vn drive 230 V (ac) 3phase		[m/s]		1.5			
	Vn drive 400 V (ac) 3phase		[m/s]		3			

COMMON RATINGS

Voltage constant ± 5%	Ke	[Vrms/m/s]	97
Pole pitch	P	[mm]	24
Temperature range	Tr	[°C]	0 ÷ 40°

SKA DDL 150.2400

MOTOR RATINGS

Continuous force(0 m/s)	Fn0	[N]	2400
Peak force	Fmax	[N]	7200
Force constant ± 5%	Kf	[N/Arms]	151
Rated current (0 m/s)	In0	[Arms]	16.27
Peak current	I fmax	[Arms]	52.9
Phase/phase res. ± 5% a 20°C	Rff	[Ohm]	1.25
Phase/phase inductance	Lff	[mH]	26
Electrical time constant	Te	[msec]	20
Attraction force	Fm	[N]	11790
Power loss	Pd	[W]	700
Thermal resistance	Rth	[°C/W]	0.13
Motor constant	Km	[N/√W]	90.7

Continuous force(0 m/s)	Fn0	[N]	
Peak force	Fmax	[N]	
Force constant ± 5%	Kf	[N/Arms]	
Rated current (0 m/s)	In0	[Arms]	
Peak current	I fmax	[Arms]	
Phase/phase res. ± 5% a 20°C	Rff	[Ohm]	
Phase/phase inductance	Lff	[mH]	
Electrical time constant	Te	[msec]	
Attraction force	Fm	[N]	
Power loss	Pd	[W]	
Thermal resistance	Rth	[°C/W]	
Motor constant	Km	[N/√W]	

THERMAL PROTECTION

Type of thermal cut-off	N C : normally closed		
Rated voltage	Vn	[Vac]	250
Rated current	In	[A]	2.5
Operative temperature	Tn	[°C]	130 °C ± 5%
Resetting temperature	Tr	[°C]	100 °C ± 15°C
Operative time		[ms]	1
Insulation class			F

Datasheet n°: SKADDL – 2008-03-00

SERIES

SKA

DDL 150

FORCE [N]

2400

MOTOR DIMENSIONS

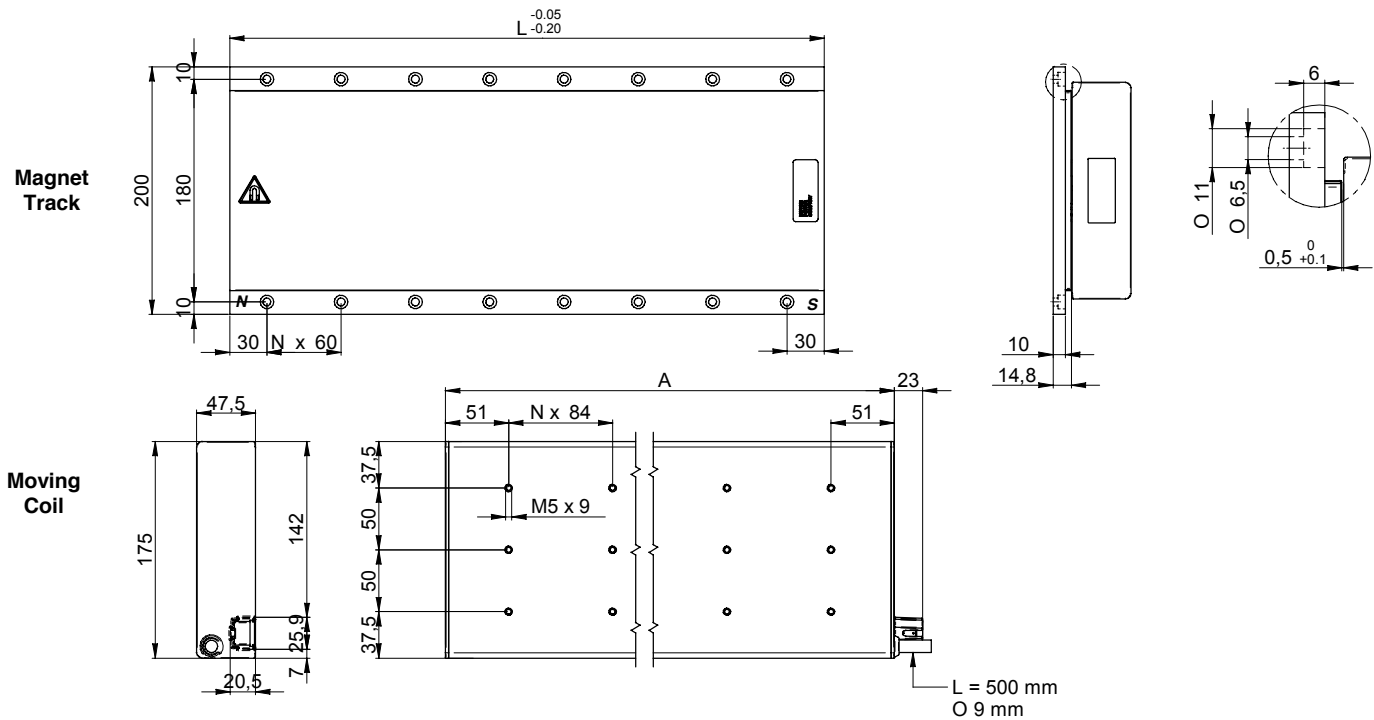

Magnet Track		Moving Coil	
Type	L (mm)	Type	A (mm)
150-120	120	150.2400	690
150-240	240		
150-480	480		

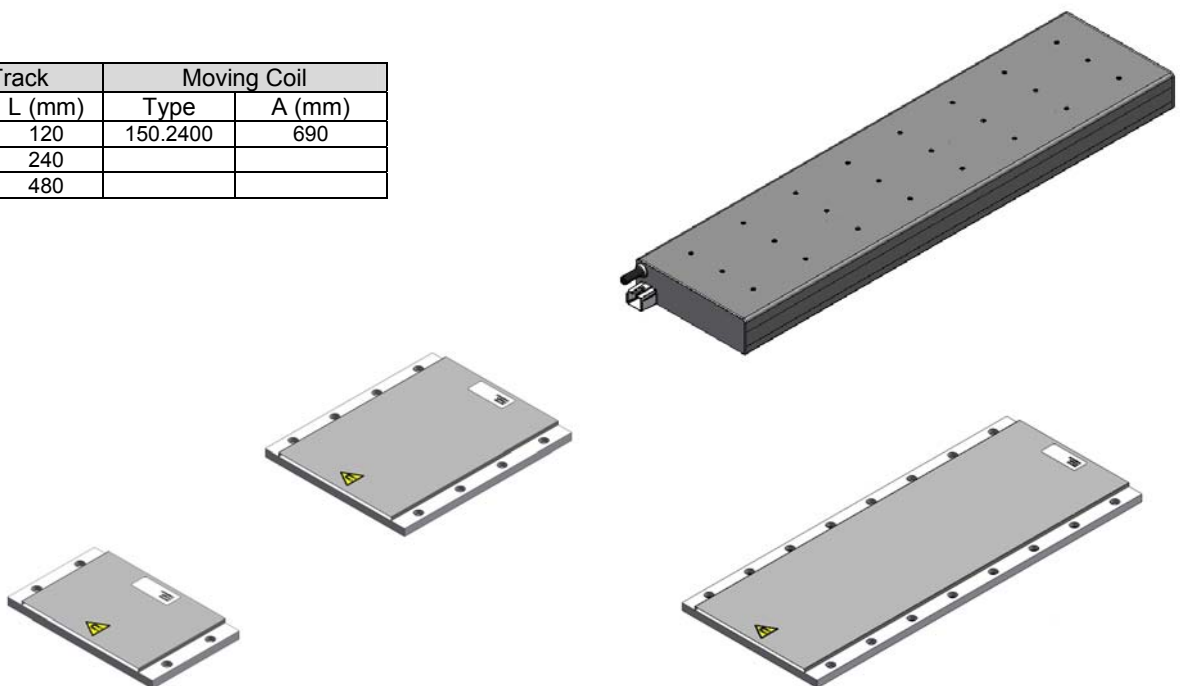



www.motorpowerco.com