



MARIO FERRI
Universal Joints



GIUNTI SERIE «G-H»	JOINTS SERIES «G-H»	Pagina / Page
Presentazione	<i>Presentation</i>	3
Giunti singoli tipo G - GB	<i>Single joints type G - GB</i>	4
Giunti doppi tipo GD - GBD	<i>Double joints type GD - GBD</i>	5
Giunti allungabili standard tipo GA	<i>Extensible standard joints type GA</i>	6 7 8 9
Giunti allungabili speciali tipo GA	<i>Extensible special joints type GA</i>	10
Giunti ad innesto rapido tipo GR	<i>Quick release joints type GR</i>	11
Giunti singoli tipo H - HB	<i>Single joints type H - HB</i>	12
Giunti doppi tipo HD - HBD	<i>Double joints type HD - HBD</i>	13
Giunti allungabili standard tipo HA	<i>Extensible standard joints type HA</i>	14 15 16 17
Giunti allungabili speciali tipo HA	<i>Extensible special joints type HA</i>	18
Giunti ad innesto rapido tipo HR	<i>Quick release joints type HR</i>	19
Mozzo a morsetto tipo CL1	<i>Clamping hub type CL1</i>	20
Mozzo a morsetto tipo CL2	<i>Clamping hub type CL2</i>	21
GIUNTI SERIE «S»	JOINTS SERIES «S»	
Presentazione	<i>Presentation</i>	23 24 25
Giunti singoli tipo S	<i>Single joints type S</i>	26
Giunti allungabili tipo A	<i>Extensible joints type A</i>	27
TRATTAMENTI SUPERFICIALI	SURFACE TREATMENTS	28
ALBERI SCANALATI «AS»	SPLINED SHAFTS «AS»	29
BOCCOLE BROCCIATE «BB»	SPLINED BUSHES «BB»	30
GIUNTI SERIE «X»	JOINTS SERIES «X»	
Presentazione	<i>Presentation</i>	32
Giunti singoli tipo X	<i>Single joints type X</i>	33
Giunti doppi tipo XD	<i>Double joints type XD</i>	34
Giunti allungabili in acciaio inox tipo XA	<i>Extensible joints in stainless steel type XA</i>	35
ALBERI SCANALATI IN ACCIAIO INOX «ASX»	SPLINED SHAFTS IN STAINLESS STEEL «ASX»	36
BOCCOLE BROCCIATE IN ACCIAIO INOX «BBX»	SPLINED BUSHES IN STAINLESS STEEL «BBX»	37
MANICOTTI DI PROTEZIONE «M»	PROTECTION MUFFS «M»	38
Criteria di scelta	<i>Selecting criteria</i>	39
Diagramma giunti serie S - G	<i>Diagram for joints series S - G</i>	40
Diagramma giunti serie H	<i>Diagram for joints series H</i>	41
Istruzioni di montaggio	<i>Instructions for fitting up</i>	42



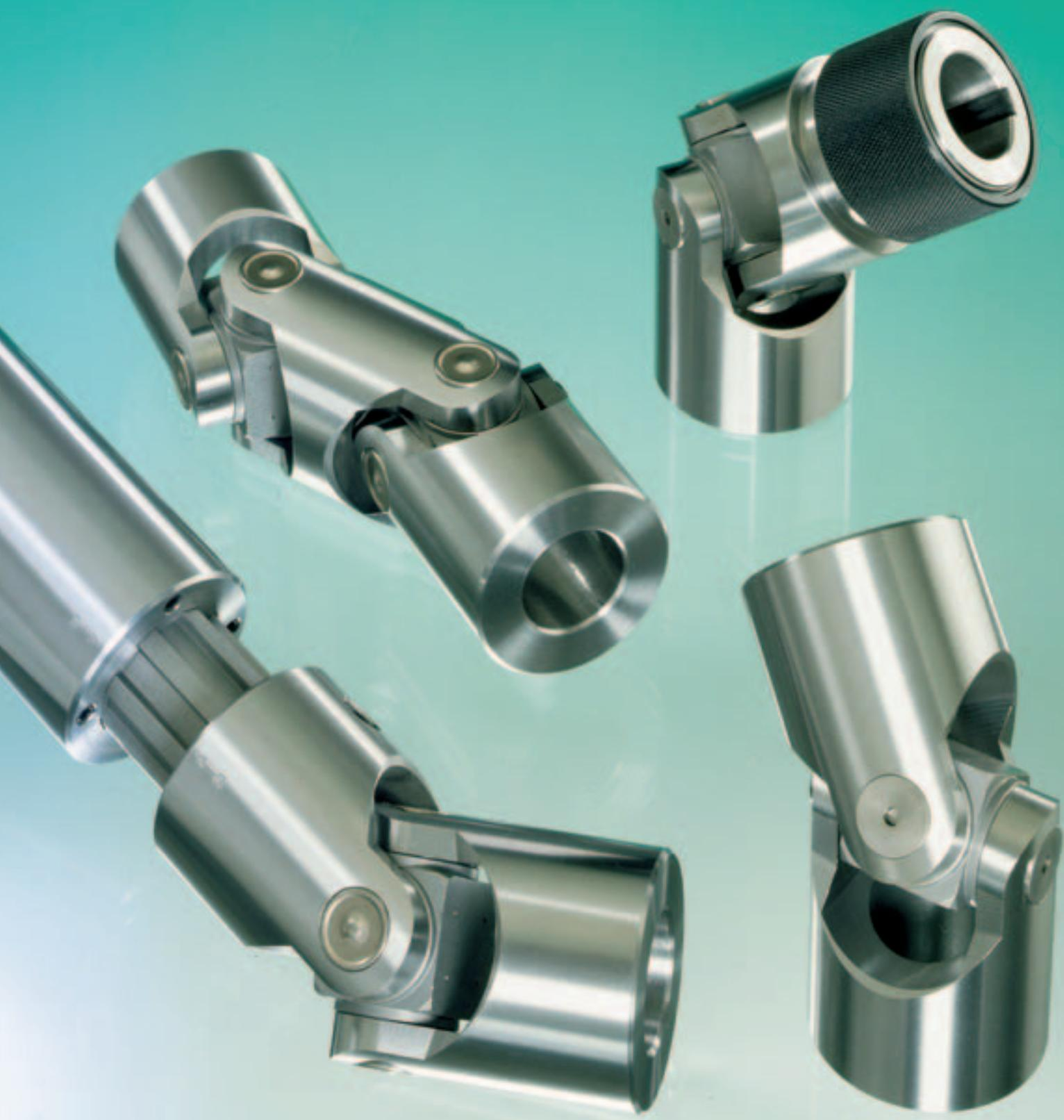



GIUNTI CARDANICI «MF» CON BUSSOLE DI SCORRIMENTO O CUSCINETTI A RULLINI - SERIE «G - H» - DIN 808

I giunti della serie «G» sono provvisti di bussole di scorrimento, mentre quelli della serie «H», di cuscinetti a rullini.

Con bussole di scorrimento, serie «G», vengono prodotte 2 versioni:

- Tipo G corrispondente alle Norme DIN 808
- Tipo GB corrispondente alle Norme DIN 808/7551

Con cuscinetti a rullini, serie «H», vengono prodotte 2 versioni:

- Tipo H corrispondente alle Norme DIN 808
- Tipo HB corrispondente alle Norme DIN 808/7551

Tutti sono composti da due semigiunti terminanti a forcella ed un nucleo centrale a crociera. Fra i perni della crociera e i fori delle forcelle vengono interposte quattro bussole di scorrimento anti-usura (serie G) oppure cuscinetti a rullini (serie H - alta velocità).

Nella serie H (alta velocità con cuscinetti a rullini) non è prevista alcuna lubrificazione. I cuscinetti montati sono del tipo lubrificati a vita, non richiedono nessuna manutenzione.

I giunti con bussole di scorrimento serie G vengono impiegati per velocità medio-basse e dove esistono carichi d'urto.

Per alte velocità e momenti torcenti relativamente bassi sono raccomandati i tipi con cuscinetti a rullini (H - HB).

Entrambe le versioni offrono alto rendimento, funzionamento silenzioso, basso coefficiente di attrito e prezzi vantaggiosi.

Tutte le superfici di contatto sono trattate e rettificata.

L'angolo di lavoro massimo è di 45° e 90° rispettivamente per i giunti a snodo singolo e doppio.

Il numero di giri massimo è di 1000/min. per la serie G mentre la serie H può raggiungere i 4000 giri/min.

Per tutte le versioni vengono prodotte trasmissioni allungabili.

«MF» UNIVERSAL JOINTS WITH PLAIN OR NEEDLE ROLLER BEARINGS SERIES «G - H» TO DIN 808

«G» series (plain bearings) is provided with sliding bushes, while «H» series with needle roller bearings.

Joints with plain bearings are available in 2 versions:

- G version to DIN 808*
- GB version to DIN 808/7551*

Joints with roller bearings are available in 2 versions:

- H version to DIN 808*
- HB version to DIN 808/7551*

They all consist of a star wheel core and 2 half-joints with fork ends. Between the pins of the star wheel and the holes of the forks, 4 wear-resistant sliding bushes (for G series) or roller bearings (for H series-high speed) are fitted in.

Neither lubrication nor maintenance is required for H series (high speed joints with roller bearings) as their bearings are lubricated for life.

Joints with plain bearings - G series - are for middle-low speeds and where there are shock loads.

For high speeds and relatively low torques types with roller bearings (H - HB) are recommended.

Both versions offer high efficiency, silent running, low friction coefficient at competitive prices.

All rubbing surfaces are hardened and ground. Maximum working angle is 45° for single joints and 90° for double joints.

Maximum speed is 1000 R.P.M. for G series, while H series can reach 4000 R.P.M.

All these joints are also supplied in telescopic version.



- Bussole di scorrimento anti-usura in acciaio cementato e temperato.
Wear resistant sliding bushes from cemented and hardened steel.
- Robusti precisi e versatili; vasto campo di applicazione.
Strong precise and versatile; wide application field.
- Angolo max : 45°. Giri max. 1000/min.
Max angle : 45°. Max speed 1000 R.P.M.
- "G" corrispondenti DIN 808 - "GB" corrispondenti DIN 808/7551
"G" to DIN 808 - "GB" to DIN 808/7551
- Esecuzioni speciali a richiesta.
Special executions on request.

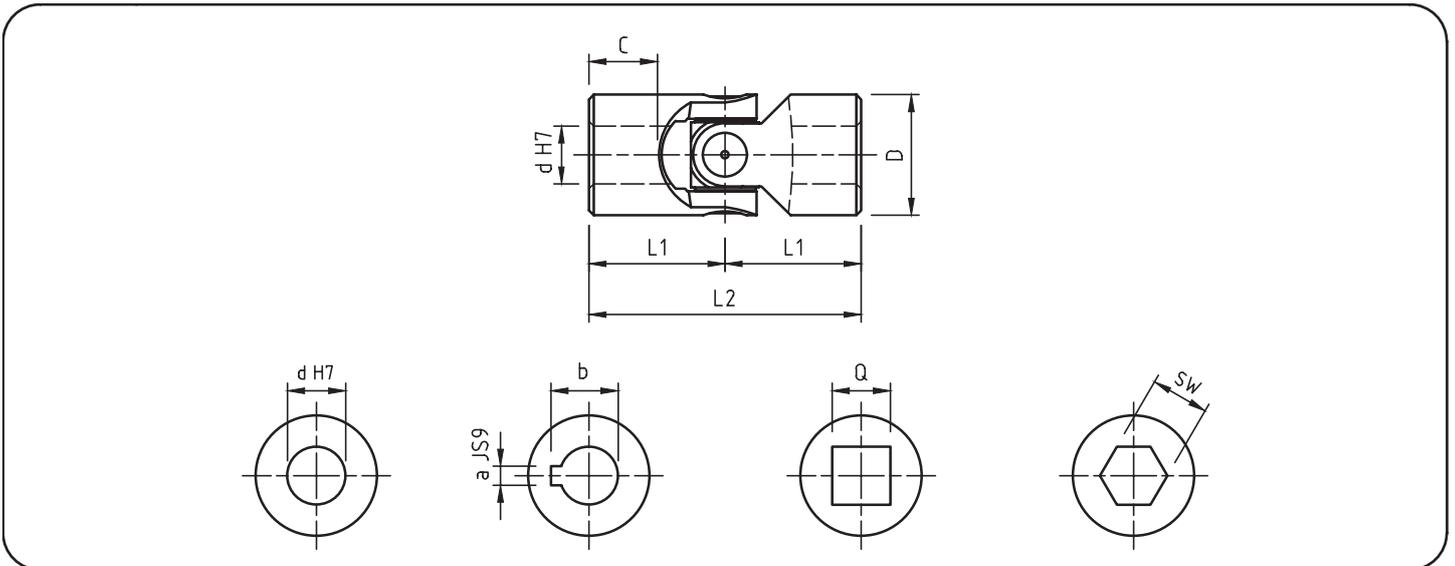

Mod. Type	Codice / Code	d	D	L2	L1	C	Codice / Code	Codice / Code	a	b	Codice / Code	Q	* SW	Peso Weight Kg
01G	SG0S 0600	6	16	34	17	8	SG0S 061C	SG0S 062C	2	7	SG0S 062Q	6	6	0,05
02G	SG0S 0800	8	16	40	20	11	SG0S 081C	SG0S 082C	2	9	SG0S 082Q	8	8	0,05
03G	SG0S 1000	10	22	48	24	12	SG0S 101C	SG0S 102C	3	11,4	SG0S 102Q	10	10	0,10
04G	SG0S 1200	12	25	56	28	13	SG0S 121C	SG0S 122C	4	13,8	SG0S 122Q	12	12	0,16
05G	SG0S 1400	14	28	60	30	14	SG0S 141C	SG0S 142C	5	16,3	SG0S 142Q	14	14	0,20
1G	SG0S 1600	16	32	68	34	16	SG0S 161C	SG0S 162C	5	18,3	SG0S 162Q	16	16	0,30
2G	SG0S 1800	18	36	74	37	17	SG0S 181C	SG0S 182C	6	20,8	SG0S 182Q	18	18	0,45
3G	SG0S 2000	20	42	82	41	18	SG0S 201C	SG0S 202C	6	22,8	SG0S 202Q	20	20	0,60
4G	SG0S 2200	22	45	95	47,5	22	SG0S 221C	SG0S 222C	6	24,8	SG0S 222Q	22	22	0,95
5G	SG0S 2500	25	50	108	54	26	SG0S 251C	SG0S 252C	8	28,3	SG0S 252Q	25	25	1,20
6G	SG0S 3000	30	58	122	61	29	SG0S 301C	SG0S 302C	8	33,3	SG0S 302Q	30	30	1,85
6G1	SG0S 3200	32	58	130	65	33	SG0S 321C	SG0S 322C	10	35,3	SG0S 322Q	30	30	2,00
7G	SG0S 3500	35	70	140	70	33	SG0S 351C	SG0S 352C	10	38,3	—	**	**	3,15
8G	SG0S 4000	40	80	160	80	38	SG0S 401C	SG0S 402C	12	43,3	—	**	**	4,60
9G	SG0S 5000	50	95	190	95	46	SG0S 501C	SG0S 502C	14	53,8	—	**	**	7,60
03GB	SGBS 1000	10	16	52	26	15	SGBS 101C	SGBS 102C	3	11,4	SGBS 082Q	8	8	0,05
04GB	SGBS 1200	12	22	62	31	18	SGBS 121C	SGBS 122C	4	13,8	SGBS 102Q	10	10	0,12
1GB	SGBS 1600	16	25	74	37	21	SGBS 161C	SGBS 162C	5	18,3	SGBS 122Q	12	12	0,20
3GB	SGBS 2000	20	32	86	43	24	SGBS 201C	SGBS 202C	6	22,8	SGBS 162Q	16	16	0,35
5GB	SGBS 2500	25	42	108	54	31	SGBS 251C	SGBS 252C	8	28,3	SGBS 202Q	20	20	0,80
6GB	SGBS 3000	30	50	132	66	38	SGBS 301C	SGBS 302C	8	33,3	SGBS 252Q	25	25	1,20
8GB	SGBS 4000	40	70	166	83	46	SGBS 401C	SGBS 402C	12	43,3	—	**	**	2,90



GIUNTI DOPPI

DOUBLE JOINTS

serie «G»

series (DIN 808)

- Bussole di scorrimento anti-usura in acciaio cementato e temperato.
Wear resistant sliding bushes from cemented and hardened steel.
- Robusti precisi e versatili; vasto campo di applicazione.
Strong precise and versatile; wide application field.
- Angolo max : 90°. Giri max. 1000/min.
Max angle : 90°. Max speed 1000 R.P.M.
- "GD" corrispondenti DIN 808 - "GBD" corrispondenti DIN 808/7551
"GD" to DIN 808 - "GBD" to DIN 808/7551
- Esecuzioni speciali a richiesta.
Special executions on request.

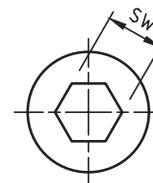
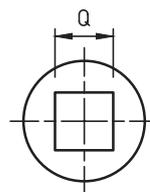
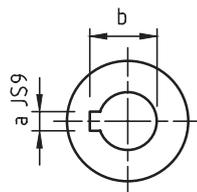
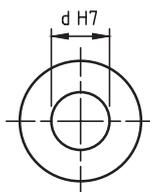
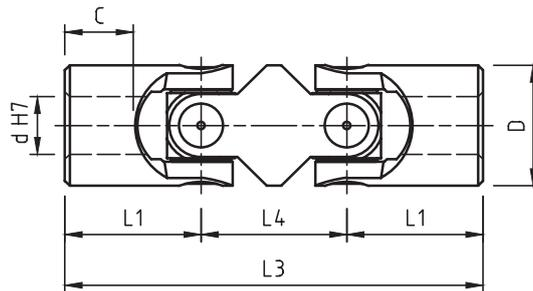

Mod. Type	Codice / Code		d	D	L3	L1	L4	C	Codice / Code		a	b	Codice / Code		Q	* SW	Peso Weight Kg
01GD	SG0D 0600		6	16	56	17	22	8	SG0D 061C	SG0D 062C	2	7	SG0D 062Q	6	6	0,08	
02GD	SG0D 0800		8	16	62	20	22	11	SG0D 081C	SG0D 082C	2	9	SG0D 082Q	8	8	0,08	
03GD	SG0D 1000		10	22	74	24	26	12	SG0D 101C	SG0D 102C	3	11,4	SG0D 102Q	10	10	0,15	
04GD	SG0D 1200		12	25	86	28	30	13	SG0D 121C	SG0D 122C	4	13,8	SG0D 122Q	12	12	0,25	
05GD	SG0D 1400		14	28	96	30	36	14	SG0D 141C	SG0D 142C	5	16,3	SG0D 142Q	14	14	0,40	
1GD	SG0D 1600		16	32	105	34	37	16	SG0D 161C	SG0D 162C	5	18,3	SG0D 162Q	16	16	0,45	
2GD	SG0D 1800		18	36	114	37	40	17	SG0D 181C	SG0D 182C	6	20,8	SG0D 182Q	18	18	0,70	
3GD	SG0D 2000		20	42	129	41	47	18	SG0D 201C	SG0D 202C	6	22,8	SG0D 202Q	20	20	1,00	
4GD	SG0D 2200		22	45	145	47,5	50	22	SG0D 221C	SG0D 222C	6	24,8	SG0D 222Q	22	22	1,55	
5GD	SG0D 2500		25	50	163	54	55	26	SG0D 251C	SG0D 252C	8	28,3	SG0D 252Q	25	25	2,00	
6GD	SG0D 3000		30	58	190	61	68	29	SG0D 301C	SG0D 302C	8	33,3	SG0D 302Q	30	30	2,90	
6GD1	SG0D 3200		32	58	198	65	68	33	SG0D 321C	SG0D 322C	10	35,3	SG0D 322Q	30	30	3,00	
7GD	SG0D 3500		35	70	212	70	72	33	SG0D 351C	SG0D 352C	10	38,3	—	**	**	4,75	
8GD	SG0D 4000		40	80	245	80	85	38	SG0D 401C	SG0D 402C	12	43,3	—	**	**	7,20	
9GD	SG0D 5000		50	95	290	95	100	46	SG0D 501C	SG0D 502C	14	53,8	—	**	**	12,00	
03GBD	SGBD 1000		10	16	74	26	22	15	SGBD 101C	SGBD 102C	3	11,4	SGBD 082Q	8	8	0,08	
04GBD	SGBD 1200		12	22	88	31	26	18	SGBD 121C	SGBD 122C	4	13,8	SGBD 102Q	10	10	0,20	
1GBD	SGBD 1600		16	25	104	37	30	21	SGBD 161C	SGBD 162C	5	18,3	SGBD 122Q	12	12	0,30	
3GBD	SGBD 2000		20	32	123	43	37	24	SGBD 201C	SGBD 202C	6	22,8	SGBD 162Q	16	16	0,50	
5GBD	SGBD 2500		25	42	155	54	47	31	SGBD 251C	SGBD 252C	8	28,3	SGBD 202Q	20	20	1,20	
6GBD	SGBD 3000		30	50	187	66	55	38	SGBD 301C	SGBD 302C	8	33,3	SGBD 252Q	25	25	1,70	
8GBD	SGBD 4000		40	70	238	83	72	46	SGBD 401C	SGBD 402C	12	43,3	—	**	**	4,30	



TRASMISSIONI ALLUNGABILI STANDARD

STANDARD EXTENSIBLE TRANSMISSIONS

serie «G»
series (DIN 808)

- Giunti serie «G» con bussole di scorrimento anti-usura.
Joints series «G» with wear resistant sliding bushes.
- Completi di cave per linguetta.
Complete with keyways.
- Ampia gamma di lunghezze per ogni modello.
Wide range of lengths per model.
- Consegna pronta.
Ready delivery.

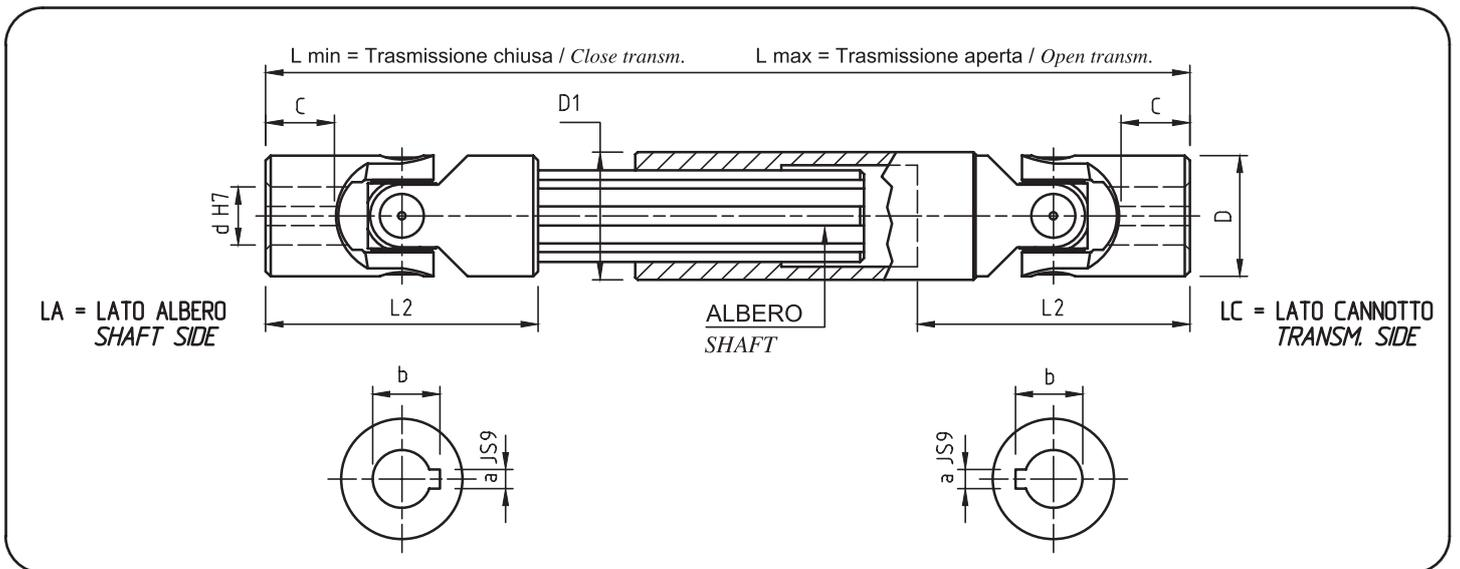

Mod. Type	Codice / Code	d	D	L2	C	L min.	L max.	corsa stroke	a	b	Albero Shaft	D1	Peso Weight Kg
03GA1	SG0A 1010	10	22	48	12	140	170	30	3	11,4	11 x 14 Z6	22	0,31
03GA15	SG0A 1015	10	22	48	12	160	200	40	3	11,4	11 x 14 Z6	22	0,36
03GA2	SG0A 1020	10	22	48	12	180	240	60	3	11,4	11 x 14 Z6	22	0,38
03GA25	SG0A 1025	10	22	48	12	230	330	100	3	11,4	11 x 14 Z6	22	0,50
04GA1	SG0A 1210	12	25	56	13	160	190	30	4	13,8	13 x 16 Z6	26	0,50
04GA15	SG0A 1215	12	25	56	13	180	225	45	4	13,8	13 x 16 Z6	26	0,56
04GA2	SG0A 1220	12	25	56	13	200	270	70	4	13,8	13 x 16 Z6	26	0,62
04GA23	SG0A 1223	12	25	56	13	220	300	80	4	13,8	13 x 16 Z6	26	0,67
04GA26	SG0A 1226	12	25	56	13	250	355	105	4	13,8	13 x 16 Z6	26	0,76
04GA29	SG0A 1229	12	25	56	13	280	420	140	4	13,8	13 x 16 Z6	26	0,84
04GA32	SG0A 1232	12	25	56	13	300	450	150	4	13,8	13 x 16 Z6	26	0,90
05GA1	SG0A 1410	14	28	60	14	170	200	30	5	16,3	13 x 16 Z6	29	0,62
05GA15	SG0A 1415	14	28	60	14	180	220	40	5	16,3	13 x 16 Z6	29	0,64
05GA18	SG0A 1418	14	28	60	14	200	260	60	5	16,3	13 x 16 Z6	29	0,72
05GA2	SG0A 1420	14	28	60	14	220	300	80	5	16,3	13 x 16 Z6	29	0,78
05GA23	SG0A 1423	14	28	60	14	250	350	100	5	16,3	13 x 16 Z6	29	0,87
05GA26	SG0A 1426	14	28	60	14	280	420	140	5	16,3	13 x 16 Z6	29	0,96



TRASMISSIONI ALLUNGABILI STANDARD

STANDARD EXTENSIBLE TRANSMISSIONS

serie «G»
series (DIN 808)

- Giunti serie «G» con bussole di scorrimento anti-usura.
Joints series «G» with wear resistant sliding bushes.
- Completi di cave per linguetta.
Complete with keyways.
- Ampia gamma di lunghezze per ogni modello.
Wide range of lengths per model.
- Consegna pronta.
Ready delivery.

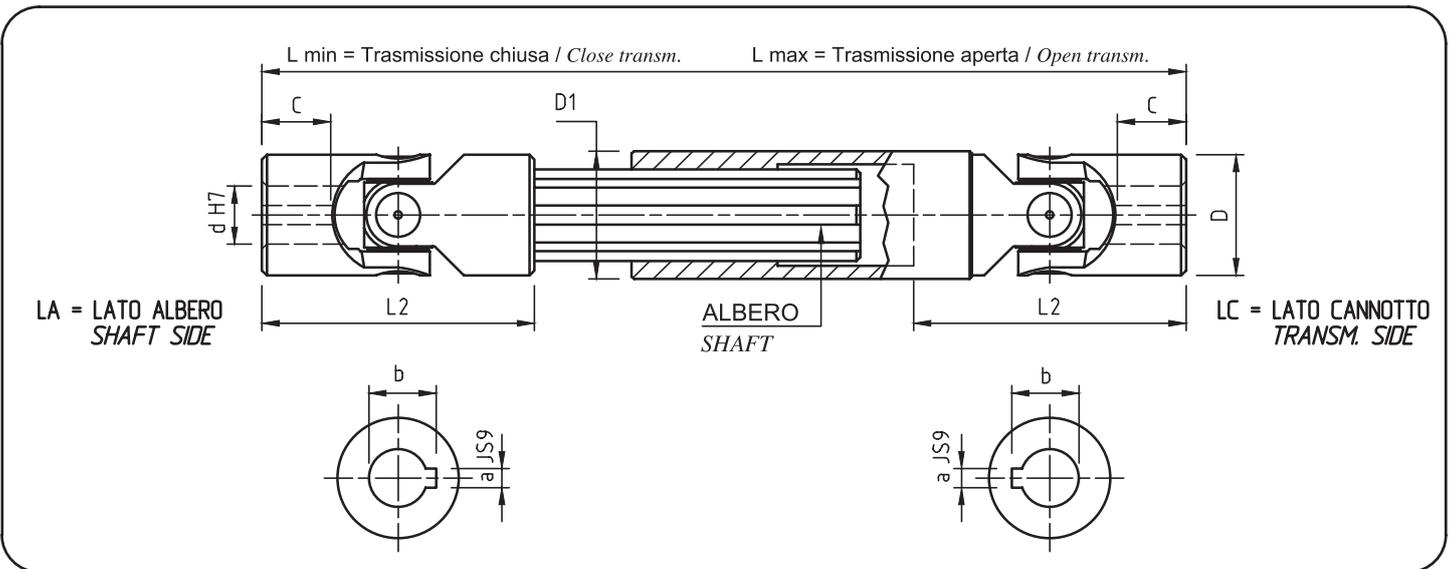

Mod. Type	Codice / Code	d	D	L2	C	L min.	L max.	corsa stroke	a	b	Albero Shaft	D1	Peso Weight Kg
05GA29	SG0A 1429	14	28	60	14	300	450	150	5	16,3	13 x 16 Z6	29	1,03
05GA32	SG0A 1432	14	28	60	14	350	550	200	5	16,3	13 x 16 Z6	29	1,17
05GA35	SG0A 1435	14	28	60	14	400	650	250	5	16,3	13 x 16 Z6	29	1,33
1GA1	SG0A 1610	16	32	68	16	190	220	30	5	18,3	16 x 20 Z6	32	0,90
1GA15	SG0A 1615	16	32	68	16	210	250	40	5	18,3	16 x 20 Z6	32	0,98
1GA2	SG0A 1620	16	32	68	16	240	320	80	5	18,3	16 x 20 Z6	32	1,10
1GA23	SG0A 1623	16	32	68	16	250	350	100	5	18,3	16 x 20 Z6	32	1,14
1GA26	SG0A 1626	16	32	68	16	275	390	115	5	18,3	16 x 20 Z6	32	1,24
1GA29	SG0A 1629	16	32	68	16	300	430	130	5	18,3	16 x 20 Z6	32	1,33
1GA32	SG0A 1632	16	32	68	16	380	590	210	5	18,3	16 x 20 Z6	32	1,60
1GA35	SG0A 1635	16	32	68	16	400	630	230	5	18,3	16 x 20 Z6	32	1,73
2GA1	SG0A 1810	18	36	74	17	230	280	50	6	20,8	18 x 22 Z6	37	1,35
2GA15	SG0A 1815	18	36	74	17	250	320	70	6	20,8	18 x 22 Z6	37	1,46
2GA18	SG0A 1818	18	36	74	17	270	370	100	6	20,8	18 x 22 Z6	37	1,55
2GA2	SG0A 1820	18	36	74	17	290	400	110	6	20,8	18 x 22 Z6	37	1,66
2GA23	SG0A 1823	18	36	74	17	300	415	115	6	20,8	18 x 22 Z6	37	1,71
2GA26	SG0A 1826	18	36	74	17	400	620	220	6	20,8	18 x 22 Z6	37	2,23
2GA29	SG0A 1829	18	36	74	17	500	820	320	6	20,8	18 x 22 Z6	37	2,75



TRASMISSIONI ALLUNGABILI STANDARD

STANDARD EXTENSIBLE TRANSMISSIONS

serie «G»
series (DIN 808)

- Giunti serie «G» con bussole di scorrimento anti-usura.
Joints series «G» with wear resistant sliding bushes.
- Completi di cave per linguetta.
Complete with keyways.
- Ampia gamma di lunghezze per ogni modello.
Wide range of lengths per model.
- Consegna pronta.
Ready delivery.

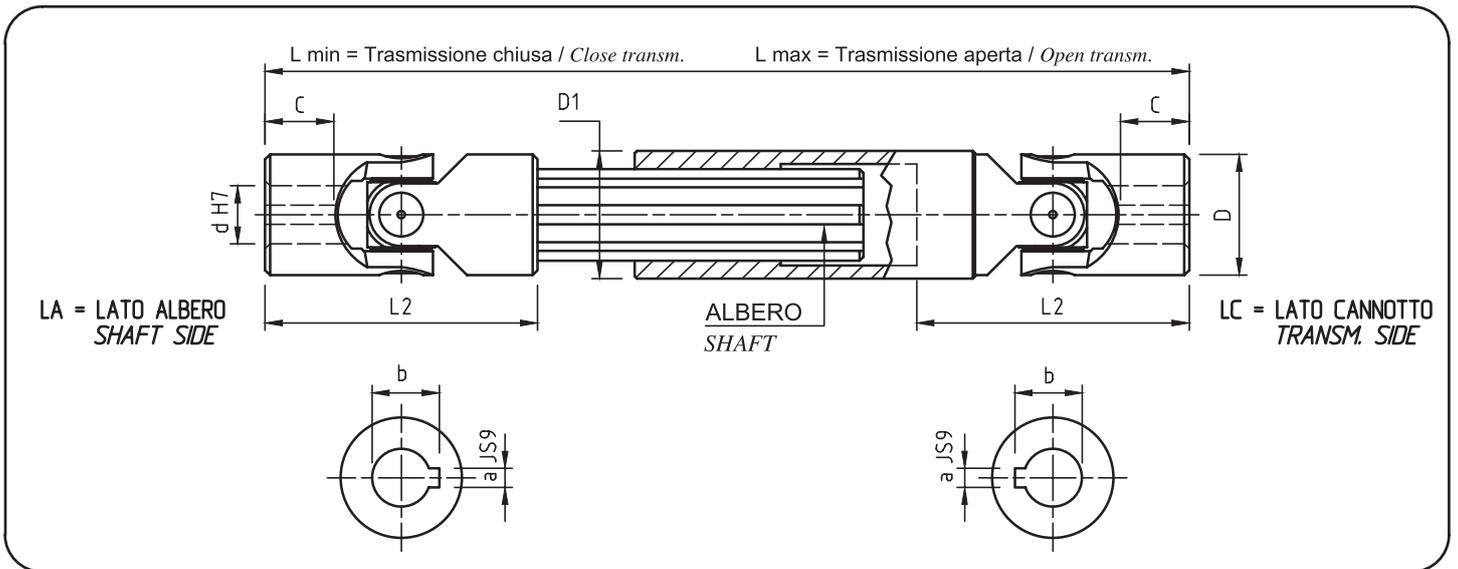

Mod. Type	Codice / Code	d	D	L2	C	L min.	L max.	corsa stroke	a	b	Albero Shaft	D1	Peso Weight Kg
3GA1	SG0A 2010	20	42	82	18	250	300	50	6	22,8	21 x 25 Z6	42	1,99
3GA15	SG0A 2015	20	42	82	18	270	340	70	6	22,8	21 x 25 Z6	42	2,12
3GA18	SG0A 2018	20	42	82	18	290	380	90	6	22,8	21 x 25 Z6	42	2,25
3GA2	SG0A 2020	20	42	82	18	320	440	120	6	22,8	21 x 25 Z6	42	2,46
3GA23	SG0A 2023	20	42	82	18	380	560	180	6	22,8	21 x 25 Z6	42	2,86
3GA26	SG0A 2026	20	42	82	18	420	640	220	6	22,8	21 x 25 Z6	42	3,13
3GA29	SG0A 2029	20	42	82	18	500	800	300	6	22,8	21 x 25 Z6	42	3,66
4GA05	SG0A 2205	22	45	95	22	250	280	30	6	24,8	23 x 28 Z6	47	2,35
4GA1	SG0A 2210	22	45	95	22	270	320	50	6	24,8	23 x 28 Z6	47	2,51
4GA15	SG0A 2215	22	45	95	22	290	350	60	6	24,8	23 x 28 Z6	47	2,67
4GA2	SG0A 2220	22	45	95	22	330	430	100	6	24,8	23 x 28 Z6	47	3,00
4GA23	SG0A 2223	22	45	95	22	350	470	120	6	24,8	23 x 28 Z6	47	3,16
4GA26	SG0A 2226	22	45	95	22	470	710	240	6	24,8	23 x 28 Z6	47	4,13
5GA1	SG0A 2510	25	50	108	26	295	345	50	8	28,3	26 x 32 Z6	52	3,39
5GA15	SG0A 2515	25	50	108	26	310	375	65	8	28,3	26 x 32 Z6	52	3,52
5GA2	SG0A 2520	25	50	108	26	350	450	100	8	28,3	26 x 32 Z6	52	3,92
5GA23	SG0A 2523	25	50	108	26	380	500	120	8	28,3	26 x 32 Z6	52	4,20
5GA26	SG0A 2526	25	50	108	26	420	590	170	8	28,3	26 x 32 Z6	52	4,59
5GA29	SG0A 2529	25	50	108	26	460	660	200	8	28,3	26 x 32 Z6	52	4,98
5GA32	SG0A 2532	25	50	108	26	500	745	245	8	28,3	26 x 32 Z6	52	5,37



TRASMISSIONI ALLUNGABILI STANDARD

STANDARD EXTENSIBLE TRANSMISSIONS

serie «G»
series (DIN 808)

- Giunti serie «G» con bussole di scorrimento anti-usura.
Joints series «G» with wear resistant sliding bushes.
- Completi di cave per linguetta.
Complete with keyways.
- Ampia gamma di lunghezze per ogni modello.
Wide range of lengths per model.
- Consegna pronta.
Ready delivery.

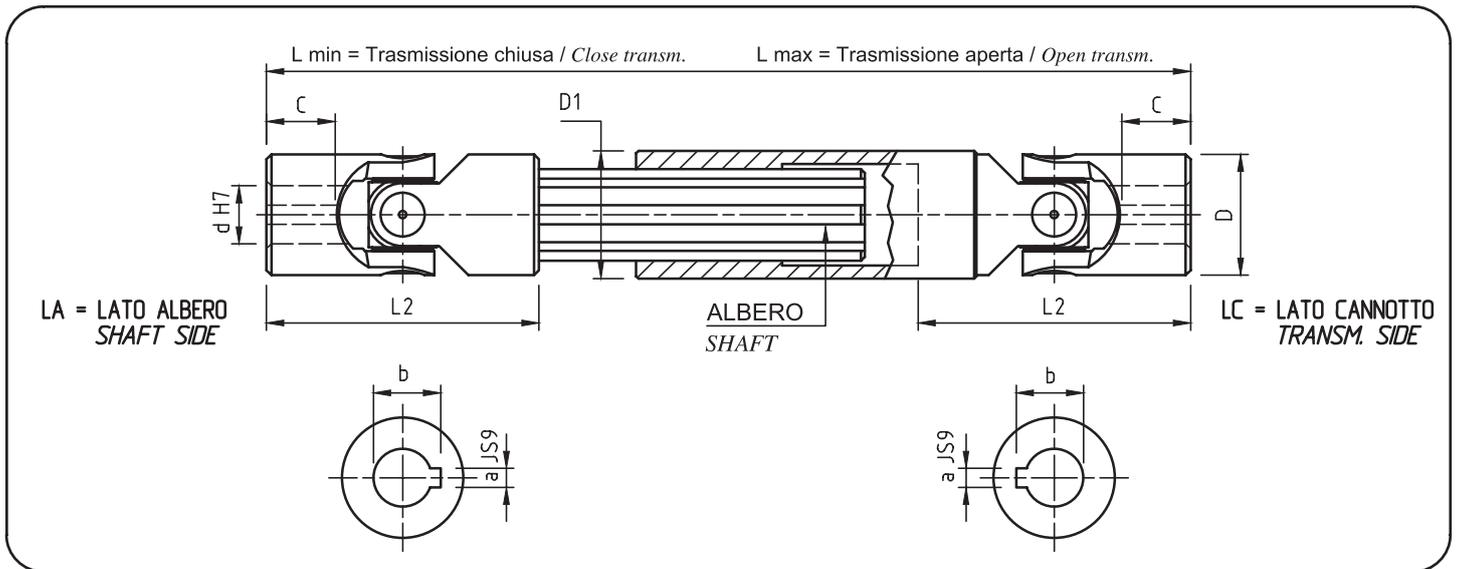

Mod. Type	Codice / Code	d	D	L2	C	L min.	L max.	corsa stroke	a	b	Albero Shaft	D1	Peso Weight Kg
6GA1	SG0A 3010	30	58	122	29	330	380	50	8	33,3	32 x 38 Z8	58	4,90
6GA15	SG0A 3015	30	58	122	29	350	420	70	8	33,3	32 x 38 Z8	58	5,17
6GA18	SG0A 3018	30	58	122	29	370	455	85	8	33,3	32 x 38 Z8	58	5,42
6GA2	SG0A 3020	30	58	122	29	400	510	110	8	33,3	32 x 38 Z8	58	5,85
6GA23	SG0A 3023	30	58	122	29	450	620	170	8	33,3	32 x 38 Z8	58	6,48
6GA26	SG0A 3026	30	58	122	29	500	720	220	8	33,3	32 x 38 Z8	58	7,14
6GA29	SG0A 3029	30	58	122	29	540	795	255	8	33,3	32 x 38 Z8	58	7,69



GIUNTI SINGOLI - INNESTO RAPIDO

Mod. GR: Bussole di Scorrimento

SINGLE JOINTS - QUICK RELEASE
Type GR: Sliding Bushes

serie «G»
series (DIN 808)

- Giri max. 1000/min.
Max speed 1000 R.P.M.
- Angolo max. 45°
Max. angle 45°

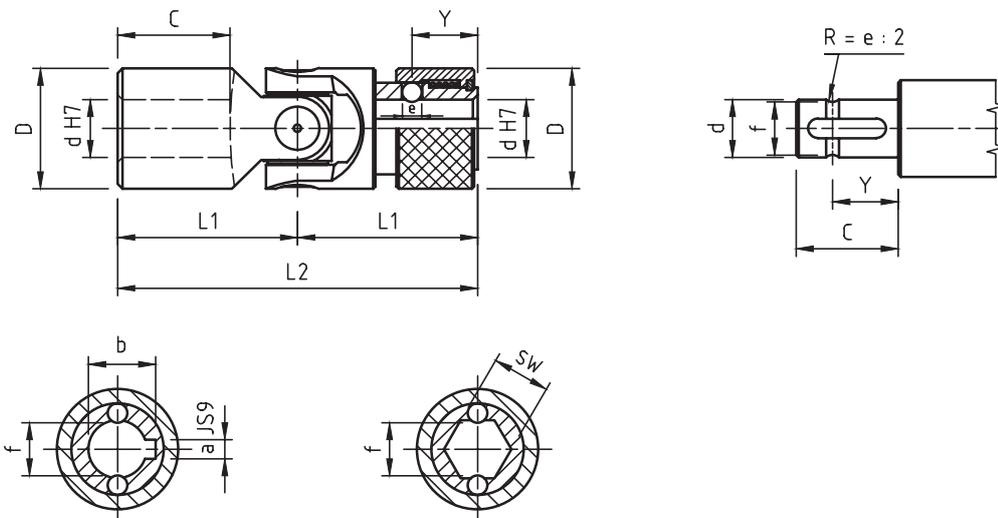

Mod. Type	d	D	L2	L1	C	Y	e	f	Codice / Code		SW	Peso Weight Kg			
02GR	8	16	52	26	14	9,5	3,5	6,3	SG0R 081C		2	9	SG0R 08SW	8	0,05
03GR	10	22	62	31	17	11,5	4	8,7 (8)	SG0R 101C		3	11	SG0R 10SW	10 (9,06)	0,12
04GR	12	25	74	37	21	13,5	4	11 (10,5)	SG0R 121C		4	13,3	SG0R 12SW	12 (11,15)	0,19
05GR	14	25	74	37	21	13,5	4	13	SG0R 141C		5	15,3	SG0R 14SW	14	0,17
1GR	16	32	86	43	24	14	6,35	14,8	SG0R 161C		5	18,3	SG0R 16SW	16	0,34
2GR	18	36	96	48	28	19	8	16	SG0R 181C		6	20,8	SG0R 18SW	18	0,48
3GR	20	42	108	54	31	19	8	18	SG0R 201C		6	22,8	SG0R 20SW	20	0,76
4GR	22	45	120	60	34	20,5	10	20	SG0R 221C		6	24,8	SG0R 22SW	22	0,97
5GR	25	50	132	66	38	20,5	10	23	SG0R 251C		8	28,3	SG0R 25SW	25	1,30
6GR	30	58	166	83	49	25	10	28	SG0R 301C		8	33,3	SG0R 30SW	30	2,13



GIUNTI SINGOLI ALTA VELOCITÀ CON CUSCINETTI A RULLINI

HIGH SPEED SINGLE JOINTS
WITH NEEDLE ROLLER BEARINGS

serie «H»
series (DIN 808)

- Cuscinetti a rullini lubrificati a vita. Nessuna manutenzione.
Roller bearings lubricated for life. No maintenance required.
- Precisi e versatili, silenziosi e scorrevoli; vasto campo di applicazione.
Precise and versatile, silent and smooth running; wide application field.
- Angolo max 45°. Giri max. 4000/min.
Max angle 45°. Max speed 4000 R.P.M.
- "H" corrispondenti DIN 808 - "HB" corrispondenti DIN 808/7551
"H" to DIN 808 - "HB" to DIN 808/7551
- Esecuzioni speciali a richiesta.
Special executions on request.

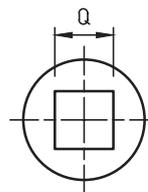
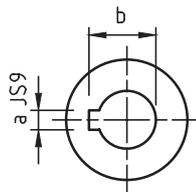
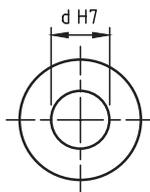
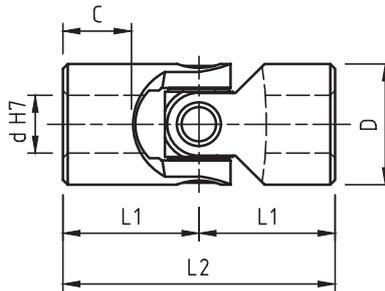

Mod. Type	Codice / Code	d	D	L2	L1	C	Codice / Code	Codice / Code	a	b	Codice / Code	Q	* SW	Peso Weight Kg
03H	SH0S 1000	10	22	48	24	12	SH0S 101C	SH0S 102C	3	11,4	SH0S 102Q	10	10	0,10
04H	SH0S 1200	12	25	56	28	13	SH0S 121C	SH0S 122C	4	13,8	SH0S 122Q	12	12	0,16
05H	SH0S 1400	14	28	60	30	14	SH0S 141C	SH0S 142C	5	16,3	SH0S 142Q	14	14	0,20
1H	SH0S 1600	16	32	68	34	16	SH0S 161C	SH0S 162C	5	18,3	SH0S 162Q	16	16	0,30
2H	SH0S 1800	18	36	74	37	17	SH0S 181C	SH0S 182C	6	20,8	SH0S 182Q	18	18	0,45
3H	SH0S 2000	20	42	82	41	18	SH0S 201C	SH0S 202C	6	22,8	SH0S 202Q	20	20	0,60
4H	SH0S 2200	22	45	95	47,5	22	SH0S 221C	SH0S 222C	6	24,8	SH0S 222Q	22	22	0,95
5H	SH0S 2500	25	50	108	54	26	SH0S 251C	SH0S 252C	8	28,3	SH0S 252Q	25	25	1,20
6H	SH0S 3000	30	58	122	61	29	SH0S 301C	SH0S 302C	8	33,3	SH0S 302Q	30	30	1,85
6H1	SH0S 3200	32	58	130	65	33	SH0S 321C	SH0S 322C	10	35,3	SH0S 322Q	30	30	2,00
7H	SH0S 3500	35	70	140	70	33	SH0S 351C	SH0S 352C	10	38,3	—	**	**	3,15
8H	SH0S 4000	40	80	160	80	38	SH0S 401C	SH0S 402C	12	43,3	—	**	**	4,60
9H	SH0S 5000	50	95	190	95	46	SH0S 501C	SH0S 502C	14	53,8	—	**	**	7,60
04HB	SHBS 1200	12	22	62	31	18	SHBS 121C	SHBS 122C	4	13,8	SHBS 102Q	10	10	0,12
1HB	SHBS 1600	16	25	74	37	21	SHBS 161C	SHBS 162C	5	18,3	SHBS 122Q	12	12	0,20
3HB	SHBS 2000	20	32	86	43	24	SHBS 201C	SHBS 202C	6	22,8	SHBS 162Q	16	16	0,35
5HB	SHBS 2500	25	42	108	54	31	SHBS 251C	SHBS 252C	8	28,3	SHBS 202Q	20	20	0,80
6HB	SHBS 3000	30	50	132	66	38	SHBS 301C	SHBS 302C	8	33,3	SHBS 252Q	25	25	1,20
8HB	SHBS 4000	40	70	166	83	46	SHBS 401C	SHBS 402C	12	43,3	—	**	**	2,90



GIUNTI DOPPI ALTA VELOCITÀ CON CUSCINETTI A RULLINI

HIGH SPEED DOUBLE JOINTS
WITH NEEDLE ROLLER BEARINGS

serie «H»
series (DIN 808)

- Cuscinetti a rullini lubrificati a vita. Nessuna manutenzione.
Roller bearings lubricated for life. No maintenance required.
- Precisi e versatili, silenziosi e scorrevoli;
vasto campo di applicazione.
*Precise and versatile, silent and smooth running;
wide application field.*
- Angolo max 90°. Giri max. 4000/min.
Max angle 90°. Max speed 4000 R.P.M.
- "HD" corrispondenti DIN 808 - "HBD" corrispondenti DIN 808/7551
"HD" to DIN 808 - "HBD" to DIN 808/7551
- Esecuzioni speciali a richiesta.
Special executions on request.

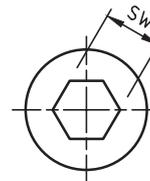
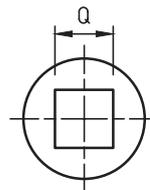
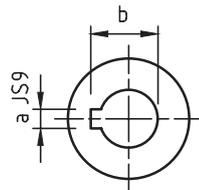
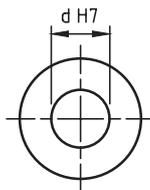
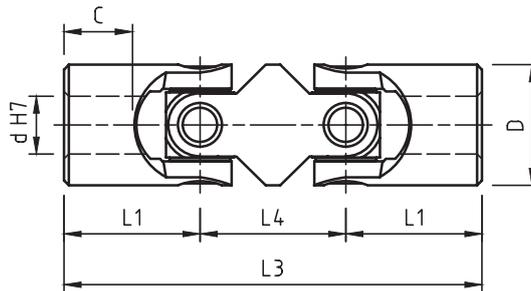

Mod. Type	Codice / Code	d	D	L3	L1	L4	C	Codice / Code		a	b	Codice / Code		Q	* SW	Peso Weight Kg
03HD	SH0D 1000	10	22	74	24	26	12	SH0D 101C	SH0D 102C	3	11,4	SH0D 102Q	10	10	0,15	
04HD	SH0D 1200	12	25	86	28	30	13	SH0D 121C	SH0D 122C	4	13,8	SH0D 122Q	12	12	0,25	
05HD	SH0D 1400	14	28	96	30	36	14	SH0D 141C	SH0D 142C	5	16,3	SH0D 142Q	14	14	0,40	
1HD	SH0D 1600	16	32	105	34	37	16	SH0D 161C	SH0D 162C	5	18,3	SH0D 162Q	16	16	0,45	
2HD	SH0D 1800	18	36	114	37	40	17	SH0D 181C	SH0D 182C	6	20,8	SH0D 182Q	18	18	0,70	
3HD	SH0D 2000	20	42	129	41	47	18	SH0D 201C	SH0D 202C	6	22,8	SH0D 202Q	20	20	1,00	
4HD	SH0D 2200	22	45	145	47,5	50	22	SH0D 221C	SH0D 222C	6	24,8	SH0D 222Q	22	22	1,55	
5HD	SH0D 2500	25	50	163	54	55	26	SH0D 251C	SH0D 252C	8	28,3	SH0D 252Q	25	25	2,00	
6HD	SH0D 3000	30	58	190	61	68	29	SH0D 301C	SH0D 302C	8	33,3	SH0D 302Q	30	30	2,90	
6HD1	SH0D 3200	32	58	198	65	68	33	SH0D 321C	SH0D 322C	10	35,3	SH0D 322Q	30	30	3,00	
7HD	SH0D 3500	35	70	212	70	72	33	SH0D 351C	SH0D 352C	10	38,3	—	**	**	4,75	
8HD	SH0D 4000	40	80	245	80	85	38	SH0D 401C	SH0D 402C	12	43,3	—	**	**	7,20	
9HD	SH0D 5000	50	95	290	95	100	46	SH0D 501C	SH0D 502C	14	53,8	—	**	**	12,00	
04HBD	SHBD 1200	12	22	88	31	26	18	SHBD 121C	SHBD 122C	4	13,8	SHBD 102Q	10	10	0,20	
1HBD	SHBD 1600	16	25	104	37	30	21	SHBD 161C	SHBD 162C	5	18,3	SHBD 122Q	12	12	0,30	
3HBD	SHBD 2000	20	32	123	43	37	24	SHBD 201C	SHBD 202C	6	22,8	SHBD 162Q	16	16	0,50	
5HBD	SHBD 2500	25	42	155	54	47	31	SHBD 251C	SHBD 252C	8	28,3	SHBD 202Q	20	20	1,20	
6HBD	SHBD 3000	30	50	187	66	55	38	SHBD 301C	SHBD 302C	8	33,3	SHBD 252Q	25	25	1,70	
8HBD	SHBD 4000	40	70	238	83	72	46	SHBD 401C	SHBD 402C	12	43,3	—	**	**	4,30	



TRASMISSIONI ALLUNGABILI ALTA VELOCITÀ STANDARD

STANDARD EXTENSIBLE TRANSMISSIONS
HIGH SPEED

serie «H»
series (DIN 808)

- Giunti serie «H» alta velocità con cuscinetti a rullini.
High speed joints series «H» with needle roller bearings.
- Completi di cave per linguetta.
Complete with keyways.
- Ampia gamma di lunghezze per ogni modello.
Wide range of lengths per model.
- Consegna pronta.
Ready delivery.

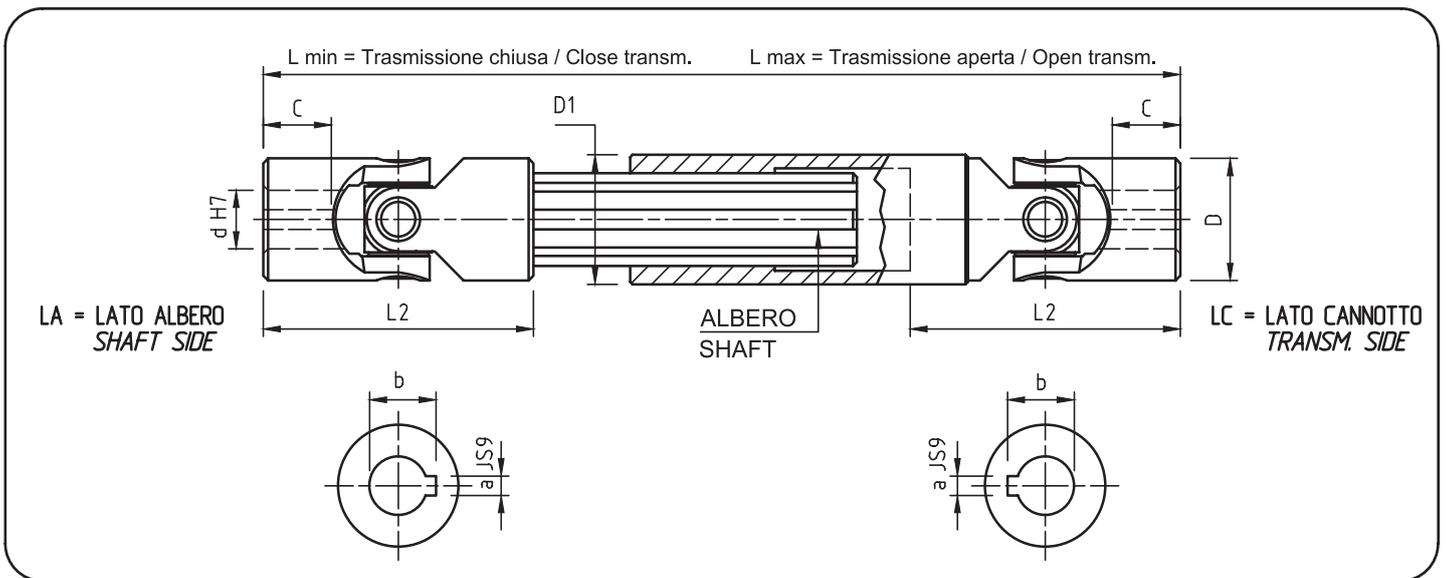

Mod. Type	Codice / Code	d	D	L2	C	L min.	L max.	corsa stroke	a	b	Albero Shaft	D1	Peso Weight Kg
03HA1	SH0A 1010	10	22	48	12	140	170	30	3	11,4	11 x 14 Z6	22	0,31
03HA15	SH0A 1015	10	22	48	12	160	200	40	3	11,4	11 x 14 Z6	22	0,36
03HA2	SH0A 1020	10	22	48	12	180	240	60	3	11,4	11 x 14 Z6	22	0,38
03HA25	SH0A 1025	10	22	48	12	230	330	100	3	11,4	11 x 14 Z6	22	0,50
04HA1	SH0A 1210	12	25	56	13	160	190	30	4	13,8	13 x 16 Z6	26	0,50
04HA15	SH0A 1215	12	25	56	13	180	225	45	4	13,8	13 x 16 Z6	26	0,56
04HA2	SH0A 1220	12	25	56	13	200	270	70	4	13,8	13 x 16 Z6	26	0,62
04HA23	SH0A 1223	12	25	56	13	220	300	80	4	13,8	13 x 16 Z6	26	0,67
04HA26	SH0A 1226	12	25	56	13	250	355	105	4	13,8	13 x 16 Z6	26	0,76
04HA29	SH0A 1229	12	25	56	13	280	420	140	4	13,8	13 x 16 Z6	26	0,84
04HA32	SH0A 1232	12	25	56	13	300	450	150	4	13,8	13 x 16 Z6	26	0,90
05HA1	SH0A 1410	14	28	60	14	170	200	30	5	16,3	13 x 16 Z6	29	0,62
05HA15	SH0A 1415	14	28	60	14	180	220	40	5	16,3	13 x 16 Z6	29	0,64
05HA18	SH0A 1418	14	28	60	14	200	260	60	5	16,3	13 x 16 Z6	29	0,72
05HA2	SH0A 1420	14	28	60	14	220	300	80	5	16,3	13 x 16 Z6	29	0,78
05HA23	SH0A 1423	14	28	60	14	250	350	100	5	16,3	13 x 16 Z6	29	0,87
05HA26	SH0A 1426	14	28	60	14	280	420	140	5	16,3	13 x 16 Z6	29	0,96



TRASMISSIONI ALLUNGABILI ALTA VELOCITÀ STANDARD

STANDARD EXTENSIBLE TRANSMISSIONS
HIGH SPEED

serie «H»
series (DIN 808)

- Giunti serie «H» alta velocità con cuscinetti a rullini.
High speed joints series «H» with needle roller bearings.
- Completi di cave per linguetta.
Complete with keyways.
- Ampia gamma di lunghezze per ogni modello.
Wide range of lengths per model.
- Consegna pronta.
Ready delivery.

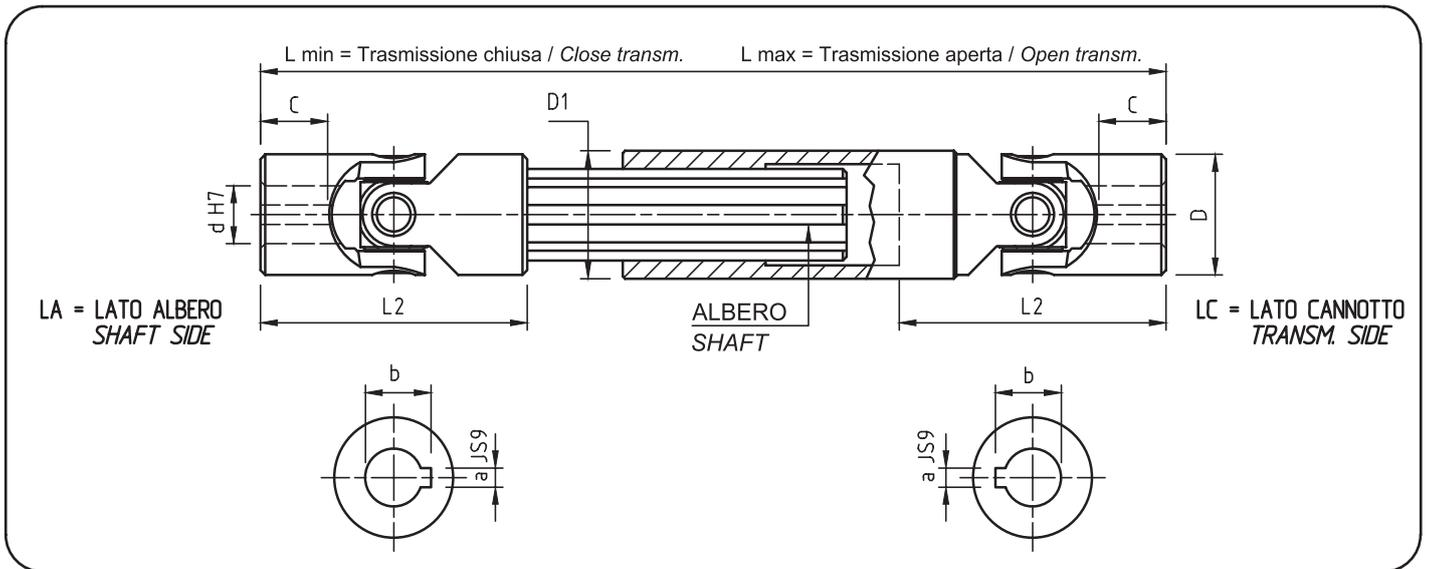

Mod. Type	Codice / Code	d	D	L2	C	L min.	L max.	corsa stroke	a	b	Albero Shaft	D1	Peso Weight Kg
05HA29	SH0A 1429	14	28	60	14	300	450	150	5	16,3	13 x 16 Z6	29	1,03
05HA32	SH0A 1432	14	28	60	14	350	550	200	5	16,3	13 x 16 Z6	29	1,17
05HA35	SH0A 1435	14	28	60	14	400	650	250	5	16,3	13 x 16 Z6	29	1,33
1HA1	SH0A 1610	16	32	68	16	190	220	30	5	18,3	16 x 20 Z6	32	0,90
1HA15	SH0A 1615	16	32	68	16	210	250	40	5	18,3	16 x 20 Z6	32	0,98
1HA2	SH0A 1620	16	32	68	16	240	320	80	5	18,3	16 x 20 Z6	32	1,10
1HA23	SH0A 1623	16	32	68	16	250	350	100	5	18,3	16 x 20 Z6	32	1,14
1HA26	SH0A 1626	16	32	68	16	275	390	115	5	18,3	16 x 20 Z6	32	1,24
1HA29	SH0A 1629	16	32	68	16	300	430	130	5	18,3	16 x 20 Z6	32	1,33
1HA32	SH0A 1632	16	32	68	16	380	590	210	5	18,3	16 x 20 Z6	32	1,60
1HA35	SH0A 1635	16	32	68	16	400	630	230	5	18,3	16 x 20 Z6	32	1,73
2HA1	SH0A 1810	18	36	74	17	230	280	50	6	20,8	18 x 22 Z6	37	1,35
2HA15	SH0A 1815	18	36	74	17	250	320	70	6	20,8	18 x 22 Z6	37	1,46
2HA18	SH0A 1818	18	36	74	17	270	370	100	6	20,8	18 x 22 Z6	37	1,55
2HA2	SH0A 1820	18	36	74	17	290	400	110	6	20,8	18 x 22 Z6	37	1,66
2HA23	SH0A 1823	18	36	74	17	300	415	115	6	20,8	18 x 22 Z6	37	1,71
2HA26	SH0A 1826	18	36	74	17	400	620	220	6	20,8	18 x 22 Z6	37	2,23
2HA29	SH0A 1829	18	36	74	17	500	820	320	6	20,8	18 x 22 Z6	37	2,75



TRASMISSIONI ALLUNGABILI ALTA VELOCITÀ STANDARD

STANDARD EXTENSIBLE TRANSMISSIONS
HIGH SPEED

serie «H»
series (DIN 808)

- Giunti serie «H» alta velocità con cuscinetti a rullini.
High speed joints series «H» with needle roller bearings.
- Completi di cave per linguetta.
Complete with keyways.
- Ampia gamma di lunghezze per ogni modello.
Wide range of lengths per model.
- Consegna pronta.
Ready delivery.

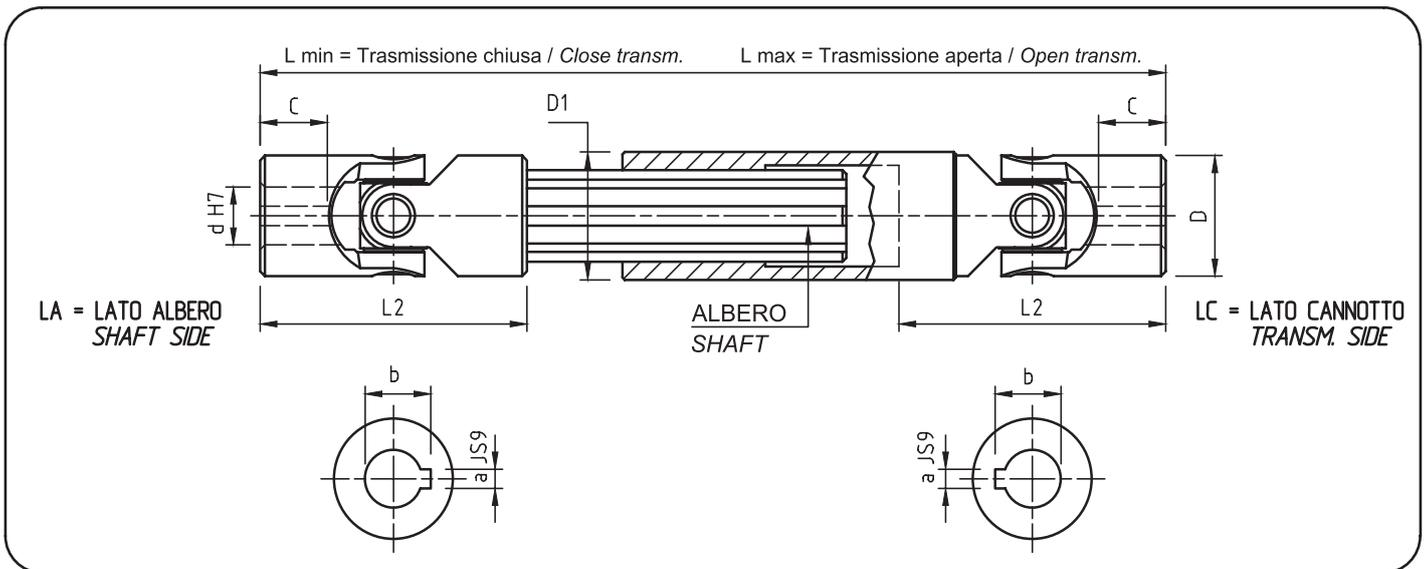

Mod. Type	Codice / Code	d	D	L2	C	L min.	L max.	corsa stroke	a	b	Albero Shaft	D1	Peso Weight Kg
3HA1	SH0A 2010	20	42	82	18	250	300	50	6	22,8	21 x 25 Z6	42	1,99
3HA15	SH0A 2015	20	42	82	18	270	340	70	6	22,8	21 x 25 Z6	42	2,12
3HA18	SH0A 2018	20	42	82	18	290	380	90	6	22,8	21 x 25 Z6	42	2,25
3HA2	SH0A 2020	20	42	82	18	320	440	120	6	22,8	21 x 25 Z6	42	2,46
3HA23	SH0A 2023	20	42	82	18	380	560	180	6	22,8	21 x 25 Z6	42	2,86
3HA26	SH0A 2026	20	42	82	18	420	640	220	6	22,8	21 x 25 Z6	42	3,13
3HA29	SH0A 2029	20	42	82	18	500	800	300	6	22,8	21 x 25 Z6	42	3,66
4HA05	SH0A 2205	22	45	95	22	250	280	30	6	24,8	23 x 28 Z6	47	2,35
4HA1	SH0A 2210	22	45	95	22	270	320	50	6	24,8	23 x 28 Z6	47	2,51
4HA15	SH0A 2215	22	45	95	22	290	350	60	6	24,8	23 x 28 Z6	47	2,67
4HA2	SH0A 2220	22	45	95	22	330	430	100	6	24,8	23 x 28 Z6	47	3,00
4HA23	SH0A 2223	22	45	95	22	350	470	120	6	24,8	23 x 28 Z6	47	3,16
4HA26	SH0A 2226	22	45	95	22	470	710	240	6	24,8	23 x 28 Z6	47	4,13
5HA1	SH0A 2510	25	50	108	26	295	345	50	8	28,3	26 x 32 Z6	52	3,39
5HA15	SH0A 2515	25	50	108	26	310	375	65	8	28,3	26 x 32 Z6	52	3,52
5HA2	SH0A 2520	25	50	108	26	350	450	100	8	28,3	26 x 32 Z6	52	3,92
5HA23	SH0A 2523	25	50	108	26	380	500	120	8	28,3	26 x 32 Z6	52	4,20
5HA26	SH0A 2526	25	50	108	26	420	590	170	8	28,3	26 x 32 Z6	52	4,59
5HA29	SH0A 2529	25	50	108	26	460	660	200	8	28,3	26 x 32 Z6	52	4,98
5HA32	SH0A 2532	25	50	108	26	500	745	245	8	28,3	26 x 32 Z6	52	5,37



TRASMISSIONI ALLUNGABILI ALTA VELOCITÀ STANDARD

STANDARD EXTENSIBLE TRANSMISSIONS
HIGH SPEED

serie «H»
series (DIN 808)

- Giunti serie «H» alta velocità con cuscinetti a rullini.
High speed joints series «H» with needle roller bearings.
- Completi di cave per linguetta.
Complete with keyways.
- Ampia gamma di lunghezze per ogni modello.
Wide range of lengths per model.
- Consegna pronta.
Ready delivery.

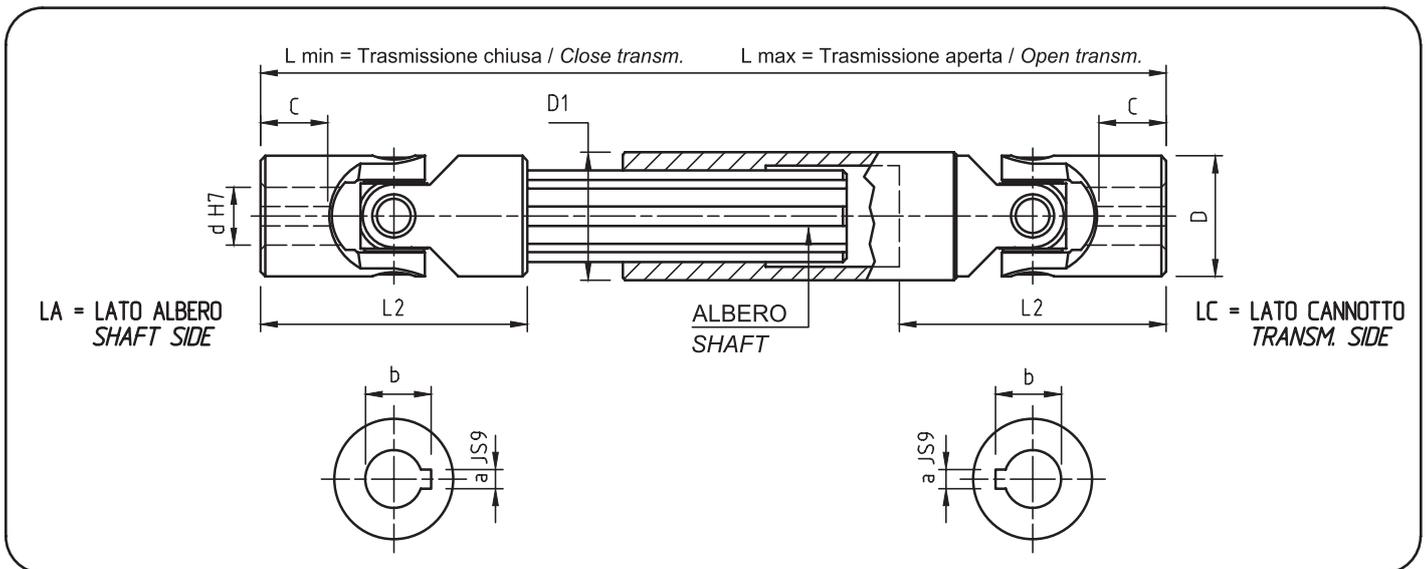

Mod. Type	Codice / Code	d	D	L2	C	L min.	L max.	corsa stroke	a	b	Albero Shaft	D1	Peso Weight Kg
6HA1	SH0A 3010	30	58	122	29	330	380	50	8	33,3	32 x 38 Z8	58	4,90
6HA15	SH0A 3015	30	58	122	29	350	420	70	8	33,3	32 x 38 Z8	58	5,17
6HA18	SH0A 3018	30	58	122	29	370	455	85	8	33,3	32 x 38 Z8	58	5,42
6HA2	SH0A 3020	30	58	122	29	400	510	110	8	33,3	32 x 38 Z8	58	5,85
6HA23	SH0A 3023	30	58	122	29	450	620	170	8	33,3	32 x 38 Z8	58	6,48
6HA26	SH0A 3026	30	58	122	29	500	720	220	8	33,3	32 x 38 Z8	58	7,14
6HA29	SH0A 3029	30	58	122	29	540	795	255	8	33,3	32 x 38 Z8	58	7,69



GIUNTI SINGOLI - INNESTO RAPIDO

Mod. HR: Cuscinetti a rullini

SINGLE JOINTS - QUICK RELEASE

Type HR: Needle Roller Bearings

serie «H»
series (DIN 808)

- Giri max. 4000/min.
Max. speed 4000 R.P.M.
- Angolo max. 45°
Max. angle 45°

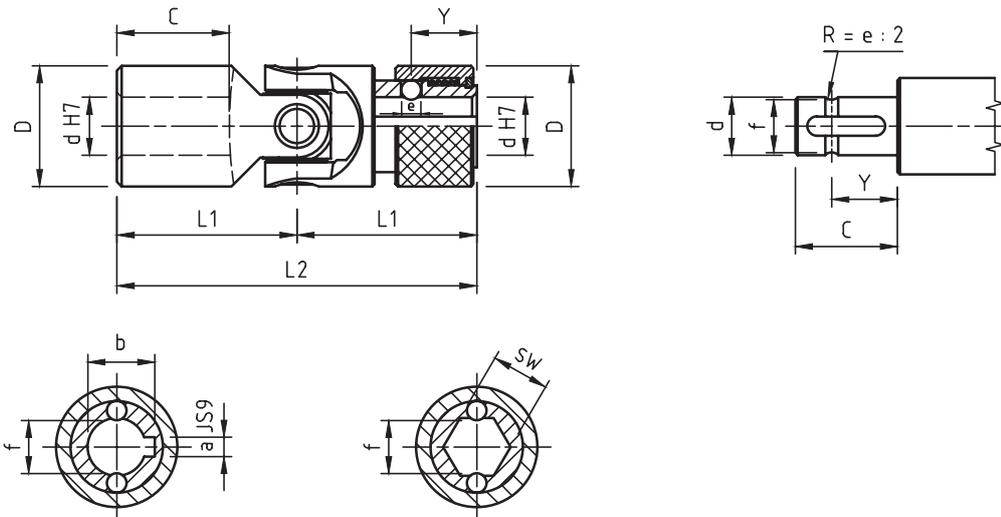

Mod. Type	d	D	L2	L1	C	Y	e	f	Codice / Code		a	b	Codice / Code		SW	Peso Weight Kg
—	—	—	—	—	—	—	—	—	—	—	—	—	—	—	—	—
03HR	10	22	62	31	17	11,5	4	8,7 (8)	SH0R 101C		3	11	SH0R 10SW		10 (9,06)	0,12
04HR	12	25	74	37	21	13,5	4	11 (10,5)	SH0R 121C		4	13,3	SH0R 12SW		12 (11,15)	0,19
05HR	14	25	74	37	21	13,5	4	13	SH0R 141C		5	15,3	SH0R 14SW		14	0,17
1HR	16	32	86	43	24	14	6,35	14,8	SH0R 161C		5	18,3	SH0R 16SW		16	0,34
2HR	18	36	96	48	28	19	8	16	SH0R 181C		6	20,8	SH0R 18SW		18	0,48
3HR	20	42	108	54	31	19	8	18	SH0R 201C		6	22,8	SH0R 20SW		20	0,76
4HR	22	45	120	60	34	20,5	10	20	SH0R 221C		6	24,8	SH0R 22SW		22	0,97
5HR	25	50	132	66	38	20,5	10	23	SH0R 251C		8	28,3	SH0R 25SW		25	1,30
6HR	30	58	166	83	49	25	10	28	SH0R 301C		8	33,3	SH0R 30SW		30	2,13



MOZZO A MORSETTO TIPO CL1

CLAMPING HUB
TYPE CL1

- Adatto per collegamenti rapidi e frequenti.
Fit for quick and frequent connections.
- Idoneo su applicazioni con presenza di vibrazioni.
Fit for applications with vibrations.
- Applicabile su giunti singoli, doppi, trasmissioni allungabili serie "G" "H".
Suitable to single, double and extensible joints "G" and "H" series.
- Esecuzioni speciali a richiesta.
Special executions on request.

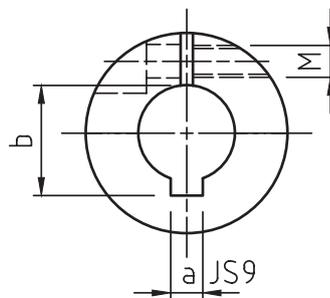
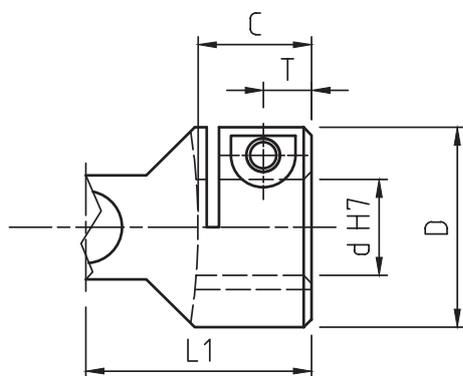

*Ta: coppia di serraggio massima viti - *Maximum screw clamping torque*

Mod. Type	d	D	L1	C	a	b	M	T	*Ta (Nm)
03CL1	10	22	24	12	3	11,4	M4	5	5
04CL1	12	25	28	13	4	13,8	M4	6	5
05CL1	14	28	30	14	5	16,3	M4	6	5
1CL1	16	32	34	16	5	18,3	M5	7	9
2CL1	18	36	37	17	6	20,8	M5	7	9
3CL1	20	42	41	18	6	22,8	M6	8	16
4CL1	22	45	47,5	22	6	24,8	M6	8	16
5CL1	25	50	54	26	8	28,3	M6	9,5	16
6CL1	30	58	61	29	8	33,3	M8	11	36
7CL1	35	70	70	33	10	38,3	M8	13	36
8CL1	40	80	80	38	12	43,3	M10	14	65
9CL1	50	95	95	46	14	53,8	M12	17,5	100



MOZZO A MORSETTO TIPO CL2

CLAMPING HUB

- Adatto per collegamenti rapidi e frequenti.
Fit for quick and frequent connections.
- Idoneo su applicazioni con presenza di vibrazioni.
Fit for applications with vibrations.
- Applicabile su giunti singoli, doppi, trasmissioni allungabili serie "G" "H".
Suitable to single, double and extensible joints "G" and "H" series.
- Esecuzioni speciali a richiesta.
Special executions on request.
- Sede per controdado di bloccaggio vite.
Lock nut screw seat.

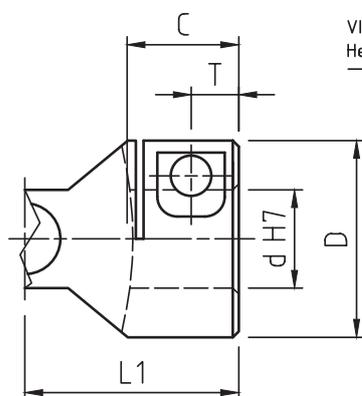

VITE A TESTA CILINDRICA CON ESAGONO INCASSATO
Hex socket head cap screw

DADO ESAGONALE
Hexagon nut

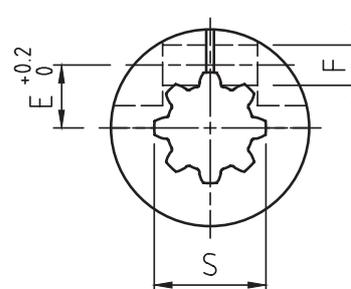
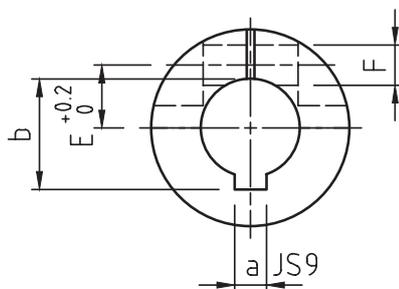
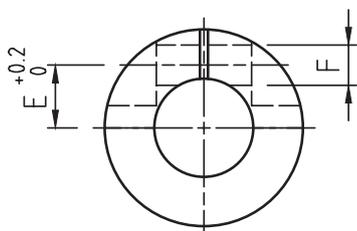
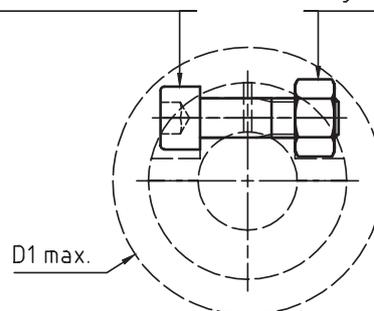

*Ta: coppia di serraggio massima viti - Maximum screw clamping torque

Mod. Type	d	D	L1	C	F	E	T	a	b	S DIN 5482	vite	dado	ingombro max	Ta (Nm)
1CL2	16	32	34	16	∅ 6,2	9	7	5	18,3	17X14 Z9	M6x25	M6	∅ 42	15
2CL2	18	36	37	17	∅ 8,2	10	7,5	6	20,8	18X15 Z10	M8x30	M8	∅ 51	25
3CL2	20	42	41	18	∅ 8,2	12	8	6	22,8	20X17 Z12	M8x35	M8	∅ 57	25
5CL2	25	50	54	26	∅ 10,2	16	12	8	28,3	25X22 Z14	M10x35	M10	∅ 68	60





GIUNTI CARDANICI «MF» A FORCELLE INTEGRALI SERIE «S» DIN 808

I Giunti a forcelle integrali «MF» Serie S sono prodotti di precisione finalizzati a fornire caratteristiche di durata eccezionali ad un prezzo competitivo.

Questo straordinario risultato è stato raggiunto grazie ad un insieme di accorgimenti di alta tecnologia costruttiva ed all'impiego di sofisticate macchine utensili.

Sono costituiti da più elementi e da materiali diversi:

- Acciaio speciale legato al Cr Ni Cementato e Temperato, per quelle parti soggette a forte tensione e usura ($R > 200 \text{ Kgf/mm}^2$ HRC 60 ~).

- Acciaio lavorabile per bussole (6) e mozzi esterni (2) per consentire forature, cave, ecc.

Caratteristica principale di questi giunti è l'assoluta assenza di perni o spine riportate.

Questa particolarità è di fondamentale importanza in determinate situazioni di emergenza, quando siano presenti forti carichi d'urto, inversioni di moto e momenti torcenti elevati.

Il nucleo centrale, composto da quattro cuscinetti a perni pieni solidali alle forcelle (5), ottenute in un sol pezzo, forma una struttura estremamente compatta. I cuscinetti si articolano nella crociera (3) unitamente ai piani di appoggio cementati delle forcelle. L'azione combinata perno/piano eleva il grado di rendimento del giunto e la sua capacità di trasmettere coppia nelle condizioni più difficili.

Le forcelle sono esposte dal mozzo in misura ridotta, allo scopo di evitare flessioni.

All'interno della crociera esistono canali che portano il lubrificante dall'ingrassatore esterno (4) ai perni. Una costante lubrificazione è assicurata dalla riserva di grasso presente nella camera ricavata al centro della crociera (3).

L'ermeticità del nucleo impedisce la fuoriuscita del lubrificante e l'inquinamento da agenti esterni.

Il numero di giri massimo consigliato è di 1000/min.

COS'E' LA CEMENTAZIONE ?

Le norme nazionali ed internazionali trascurano spesso gli aspetti qualitativi ed esprimono esclusivamente concetti di intercambiabilità dimensionale.

«MF» UNIVERSAL JOINTS WITH INTEGRAL YOKES «S» SERIES DIN 808

Integral yokes «MF» joints - S series are precision products studied to ensure exceptionally long life at competitive prices.

This extraordinary result has been achieved thanks to construction high technology devices and sophisticated machine tools.

They are made of several components and of different materials:

- *Special nickel chrome alloy steel cemented and hardened for those parts which are subject to high stress and wear ($R > 200 \text{ Kgf/mm}^2$ HRC 60 ~).*

- *Mild steel for inner hubs (6) and outer sleeves (2) to allow pinning, keyways, etc.*

The main characteristic of these joints is the absolute lack of carried journals or pins: this is fundamental in some emergency situations such as heavy shock loads, motion reversals and high torques.

Being the 4 yokes (5) and their solid pins machined from one piece, the result is an extremely compact central block. The pins articulate in the central block (3) together with the cemented bearing surface of the yokes. The combined action pin/surface raises the level of the joint output and its capability to transmit power (or torque) even in the most severe conditions.

Yokes are exposed for a minimum part (out of sleeves) to avoid bendings.

In the central block cavity there are channels bringing the lubricant from the outside grease valve (4) to the pins. A constant lubrication is ensured by the grease reserve in the central block (3) chamber. Such a hermetic core structure prevents both from lubricant losses and pollution by outside agents. The maximum suggested speed is 1000 R.P.M.

WHAT'S CEMENTATION ?

National and international standards often disregard quality aspects, just dealing with size interchangeability subjects.

I giunti cardanici «MF», pur rispettando dette norme, possiedono caratteristiche costruttive, frutto di decenni di esperienze.

Non tutti i giunti cardanici in commercio, sottoposti a carico, hanno lo stesso rendimento.

Una differenza importante è quella derivante dalle proprietà metallurgiche e meccaniche del materiale con cui essi sono costruiti, in altre parole dalla qualità dell'acciaio e dai trattamenti termici eseguiti sui vari componenti.

A differenza di altri giunti costruiti in acciaio a tutta tempera, i giunti «MF» sono esclusivamente in acciaio legato da cementazione.

La cementazione consiste in un arricchimento superficiale di carbonio su acciaio ad alta resistenza al fine di conferirgli un' elevata durezza superficiale.

L'acciaio viene riscaldato in un ambiente (atmosfera controllata) capace di cedergli carbonio: al di sopra di una certa temperatura si ha sviluppo di carbonio allo stato nascente che si diffonde negli strati superficiali dell'acciaio.

Facendo seguire a questa operazione una tempera/rinvenimento si ottiene uno strato superficiale di elevata durezza ($HRC > 60$) ed un nucleo capace di sopportare sollecitazioni di flessione ed urto senza deformazioni e rotture. Il miglioramento della resistenza a fatica di un acciaio cementato è del 50%.

Besides respecting those standards, «MF» universal joints have high quality construction characteristics, outcome of decades of experience.

Not every universal joint on the market has the same output when subject to load. A substantial difference is represented by the metallurgical and mechanical properties of the materials, that is steel quality and heating treatments executed on the different components.

While other manufacturers use steel for only hardening, «MF» joints are exclusively made from cement alloy steel.

Cementation consists of a superficial carbon enrichment to a high resilience steel to give the surface the utmost grade of hardness. The steel is heated in a particular environment (controlled atmosphere) able to transmit carbon to it: over a certain temperature nascent state carbon develops expanding into the superficial layers of the steel.

By a following hardening, we obtain a superficial layer of great hardness ($HRC > 60$) and a core able to support bending and shock stresses without deformations or breakings.

By a cemented steel we get a 50 % improvement of the fatigue strength.

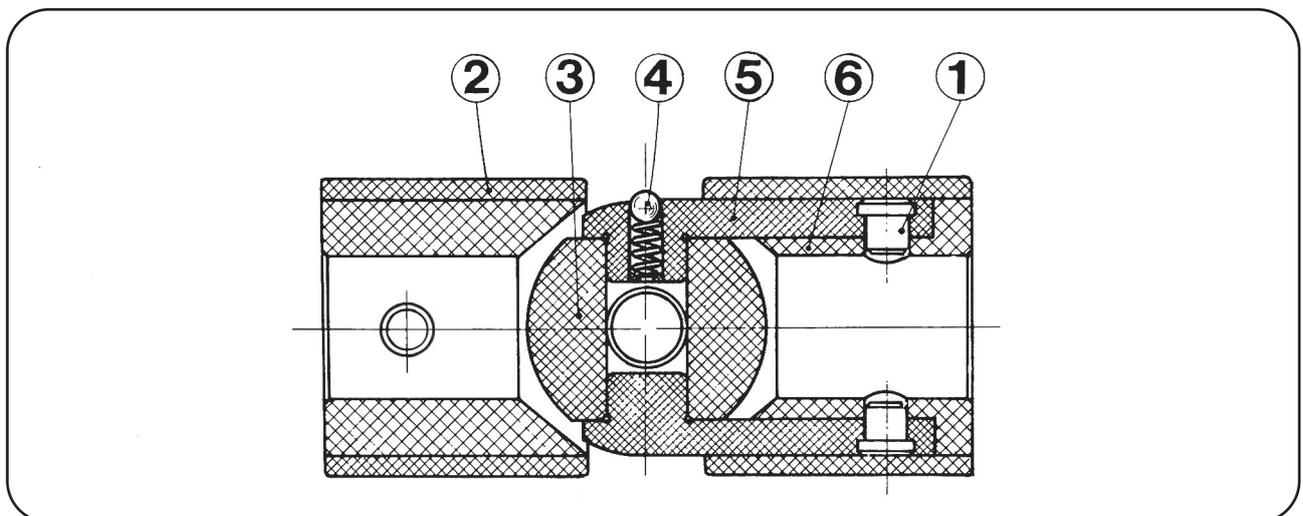

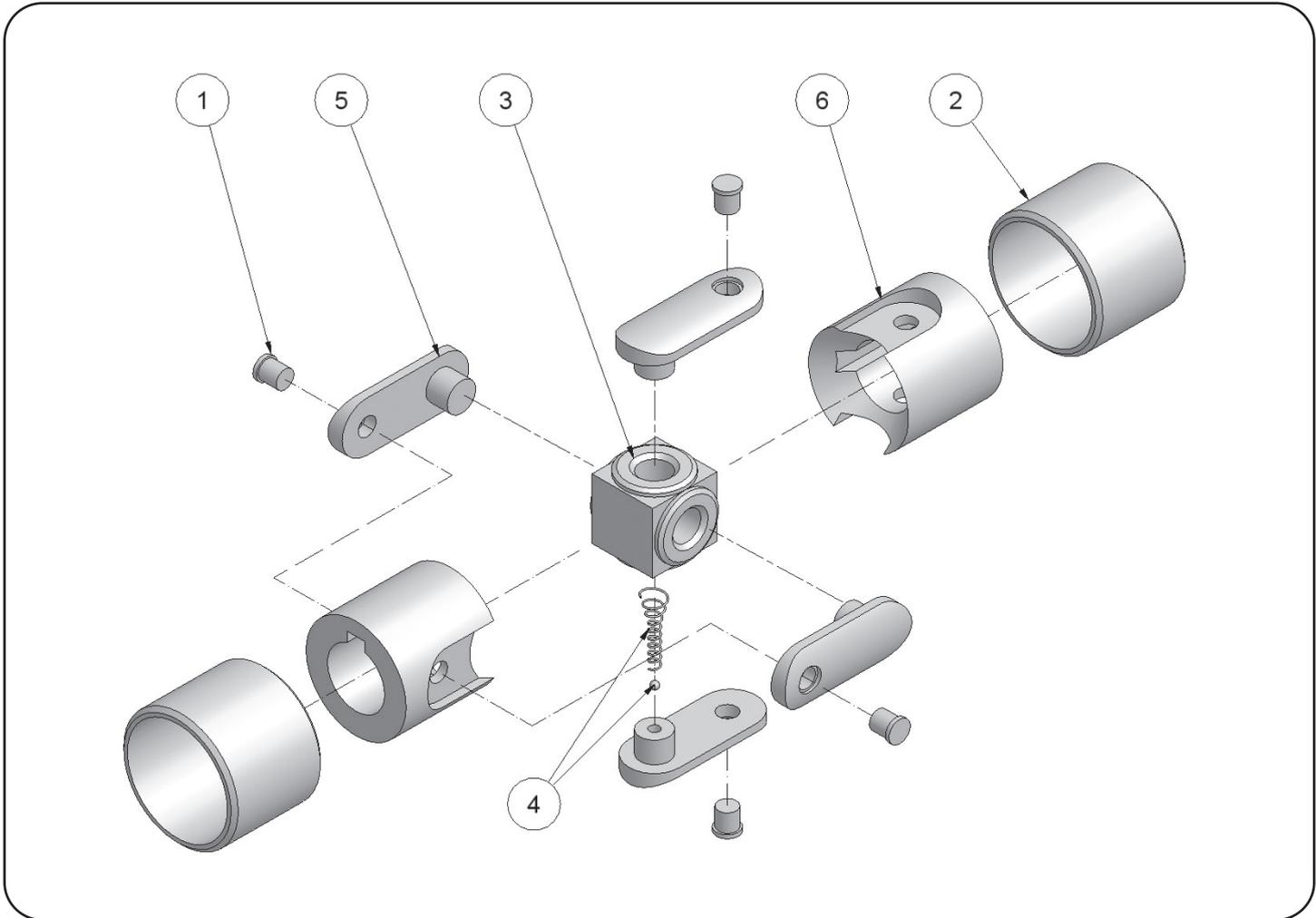



GIUNTI SINGOLI

SINGLE JOINTS

serie «S»
series (DIN 808)

- Nucleo e forcelle integrali in acc. Cr. Ni. cementato e temperato
HRC > 60, R = > 200 Kg/mm².
Central block and forks from one piece of Nickel Chrome steel cemented and hardened HRC > 60, R = > 200 Kg/sq.mm.
- Elevata resistenza usura, lunga durata.
High wear resistance, long life.
- Prelubrificati. Ingrassatore incorporato.
Pre-lubricated. Greaser built-in.
- Angolo max : 45°. Giri max. 1000/min.
Max angle : 45°. Max speed 1000 R.P.M.
- Esecuzioni speciali a richiesta.
Special executions on request.

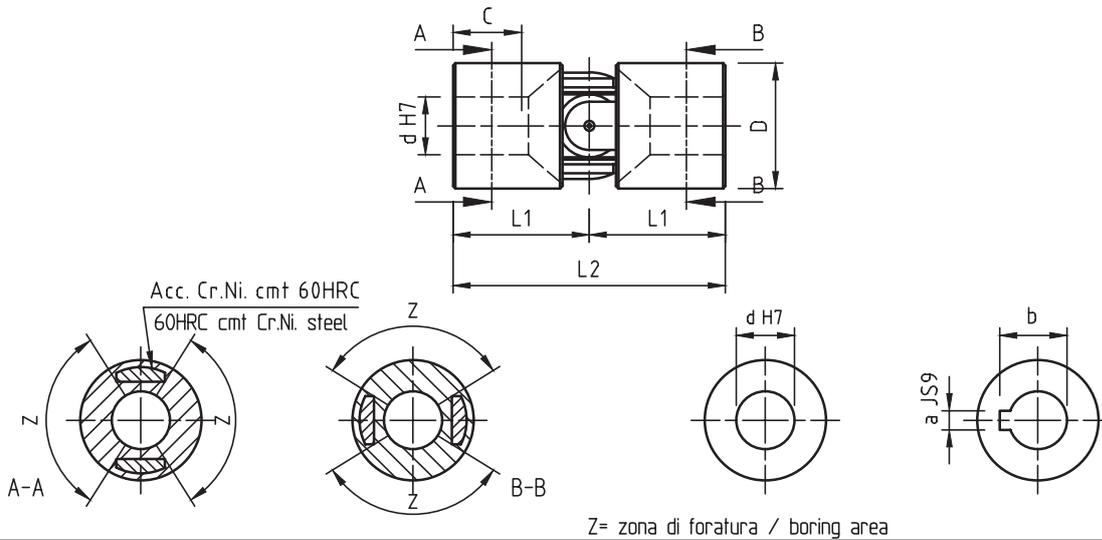

Mod. Type	Codice / Code	d	D	L2	L1	C	Codice / Code	Codice / Code	a	b	Peso Weight Kg
01S	SS0S 0600	6	16	34	17	9	—	—	—	—	0,05
02S	SS0S 0800	8	18	40	20	11	—	—	—	—	0,06
03S	SS0S 1000	10	22	48	24	14	SS0S 101C	SS0S 102C	3	11,4	0,11
04S	SS0S 1200	12	26	56	28	16	SS0S 121C	SS0S 122C	4	13,8	0,17
05S	SS0S 1400	14	29	60	30	17	SS0S 141C	SS0S 142C	5	16,3	0,22
1S	SS0S 1600	16	32	68	34	20	SS0S 161C	SS0S 162C	5	18,3	0,32
2S	SS0S 1800	18	37	74	37	21	SS0S 181C	SS0S 182C	6	20,8	0,47
3S	SS0S 2000	20	42	82	41	23	SS0S 201C	SS0S 202C	6	22,8	0,67
4S	SS0S 2200	22	47	95	47,5	25	SS0S 221C	SS0S 222C	6	24,8	1,00
5S	SS0S 2500	25	52	108	54	29	SS0S 251C	SS0S 252C	8	28,3	1,35
6S	SS0S 3000	30	58	122	61	34	SS0S 301C	SS0S 302C	8	33,3	1,85



TRASMISSIONI ALLUNGABILI

EXTENSIBLE TRANSMISSIONS

serie «S»
series (DIN 808)

● Giunti di elevata qualità serie «S».
High quality joints series «S».

● Lunghezze min. e max. a richiesta:
Min. and max. lengths on request:

$$\frac{L. MIN.}{MIN. L.} > \frac{L. MAX. + 2 L2 + B}{2} \quad \text{CORSAX} < \frac{L. MAX. - 2 L2 - B}{2}$$

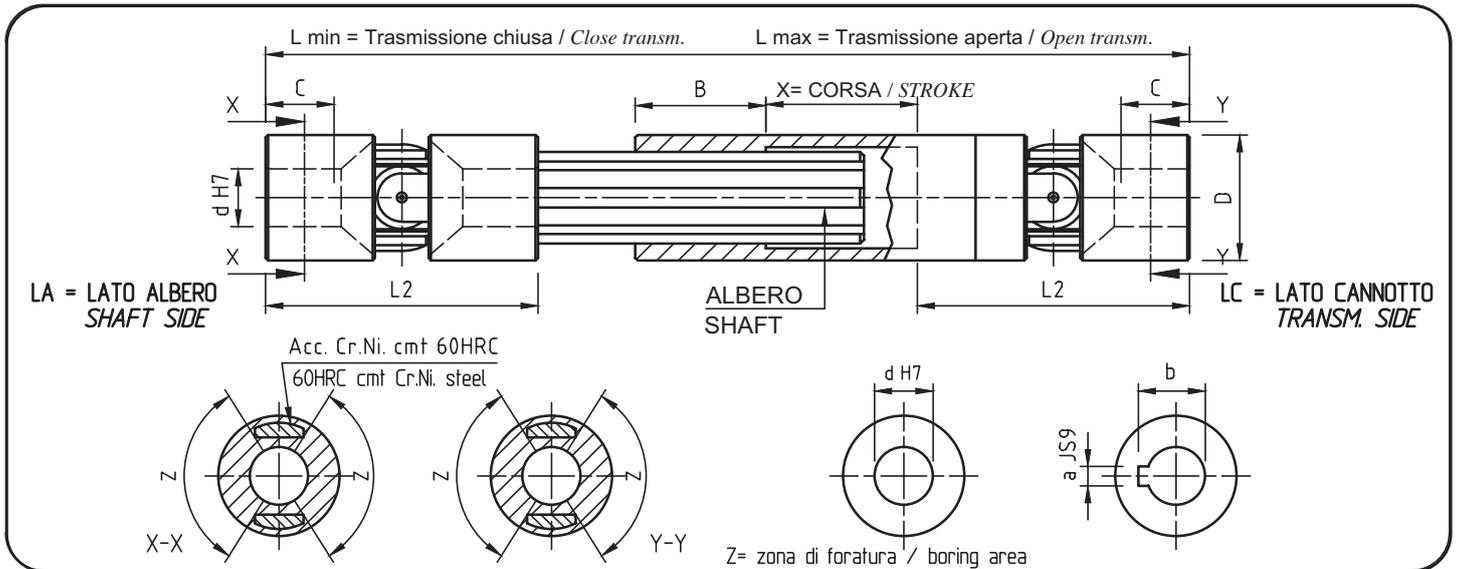

Mod. Type	d	D	L2	C	L min.	L max.	x = corsa / stroke	B	a	b	Albero Shaft
					a richiesta - on request		a richiesta - on request				
01A	6	16	34	9	←	→	—	25	—	—	SW 8
02A	8	18	40	11	←	→	—	30	—	—	SW 10
03A	10	22	48	14	←	→	—	30	3	11,4	11 x 14 Z6
04A	12	26	56	16	←	→	—	40	4	13,8	13 x 16 Z6
05A	14	29	60	17	←	→	—	40	5	16,3	13 x 16 Z6
1A	16	32	68	20	←	→	—	40	5	18,3	16 x 20 Z6
2A	18	37	74	21	←	→	—	40	6	20,8	18 x 22 Z6
3A	20	42	82	23	←	→	—	45	6	22,8	21 x 25 Z6
4A	22	47	95	25	←	→	—	45	6	24,8	23 x 28 Z6
5A	25	52	108	29	←	→	—	45	8	28,3	26 x 32 Z6
6A	30	58	122	34	←	→	—	50	8	33,3	32 x 38 Z8



TRATTAMENTI SUPERFICIALI

Realizziamo diversi tipi di rivestimenti galvanici superficiali anticorrosivi ed antiusura, nel rispetto delle norme internazionali. Trattamenti di zincatura elettrolitica a freddo, brunitura, nichelatura chimica. Il nostro ufficio tecnico è a disposizione per valutare la fattibilità di qualsiasi trattamento superficiale richiesto.



Zincatura trivalente iridescente alta resistenza / *Electro-galvanized treatment high resistance*



Zincatura trivalente verde militare / *Electro-galvanized treatment militar green*



Brunitura / *Burnishing treatment*



Nichelatura chimica / *Nichel plating*

SURFACE TREATMENTS

We carry out different types of anti-corrosive and wear-resistant galvanic treatments, in compliance with international standards. Cold electro-galvanized treatment, burnishing and chemical nickel-plating. Our technical department is available to evaluate feasibility of any surface treatment required.

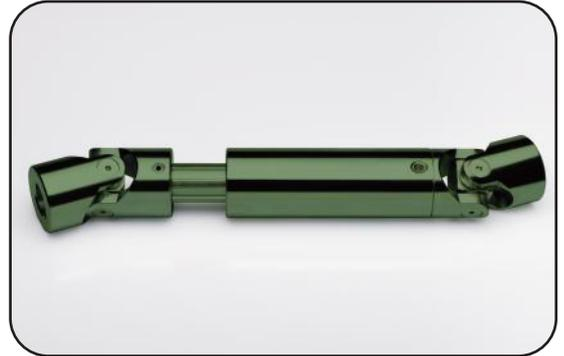



- Materiale: C40/C45
Material: C40/C45
- Toll. rettilineità lineare max. 0,8mm/m - Toll. rettilineità torsionale max. 0,5mm/m.
Linear straightness tol. max. 0,8mm/m - Torsional straightness tol. max. 0,5mm/m.
- Lunghezza standard: 1 metro.
Stock length: 1 meter.
- Altre lunghezze a richiesta.
Other lengths on request.

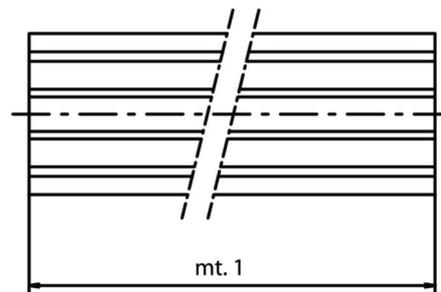
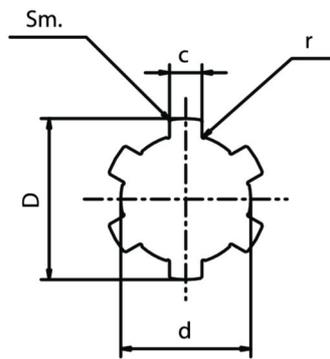
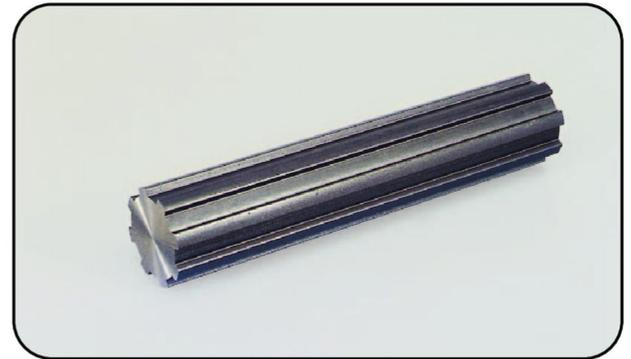

Mod. Type	Codice / Code	D	d	c	Z	Sez. / Section mm ²	Peso/Weight Kg/m	Tolleranze - Tolerances			Sm. 45°	r
								D	d	c		
11AS	SAS0 1100	14	11	3	6	121,9	0,949	-0,07 -0,20	0,00 -0,08	-0,03 -0,08	0,2	0,2
13AS	SAS0 1300	16	13	3,5	6	164,1	1,287	-0,07 -0,20	0,00 -0,08	-0,03 -0,08	0,2	0,2
16AS	SAS0 1600	20	16	4	6	243,4	1,911	-0,07 -0,25	0,00 -0,08	-0,03 -0,08	0,2	0,2
18AS	SAS0 1800	22	18	5	6	312,4	2,453	-0,07 -0,25	0,00 -0,08	-0,03 -0,08	0,2	0,2
21AS	SAS0 2100	25	21	5	6	399,8	3,139	-0,07 -0,27	0,00 -0,08	-0,03 -0,08	0,2	0,2
23AS	SAS0 2300	28	23	6	6	505,2	3,964	-0,07 -0,27	0,00 -0,08	-0,03 -0,08	0,3	0,2
26AS	SAS0 2600	32	26	6	6	638,6	5,008	-0,07 -0,27	0,00 -0,08	-0,03 -0,08	0,3	0,3
32AS	SAS0 3200	38	32	6	8	947,8	7,433	-0,07 -0,27	0,00 -0,08	-0,03 -0,08	0,3	0,3
36AS	SAS0 3600	42	36	7	8	1185,3	9,302	-0,07 -0,27	0,00 -0,08	-0,03 -0,08	0,3	0,3
42AS	SAS0 4200	48	42	8	8	1576,7	12,371	-0,07 -0,27	0,00 -0,08	-0,03 -0,08	0,3	0,3
46AS	SAS0 4600	54	46	9	8	1949	15,300	-0,07 -0,27	0,00 -0,08	-0,03 -0,08	0,5	0,5



BOCCOLE BROCCIATE

SPLINED BUSHES

serie «**BB**»
series

- Materiale: 11SMnPb37
Material: 11SMnPb37
- Esecuzioni speciali a richiesta.
Special executions on request.

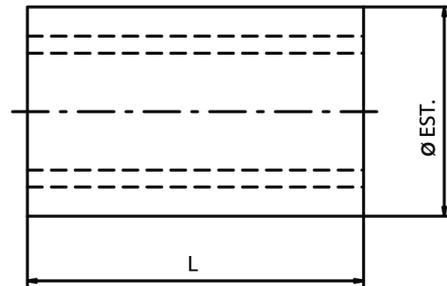
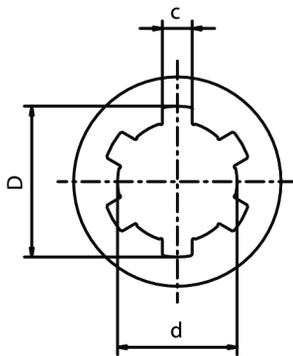
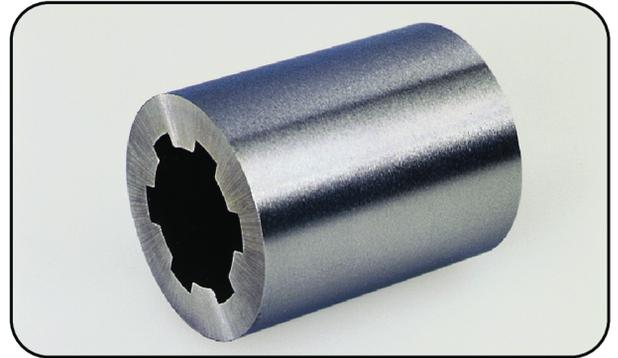

Mod. Type	Codice / Code	D	d	c	Z	Ø	TOLL.	L	Rif. uni Uni Ref.	Peso Weight Kg	Tolleranze - Tolerances		
											D (H11)	d	c (D9)
11BB	SBB0 1100	14	11	3	6	18,75	h8	30	11 UNI	0,033	+0,11 +0,00	+0,040 +0,020	+0,045 +0,020
13BB	SBB0 1300	16	13	3,5	6	21,75	h8	40	13 UNI	0,062	+0,11 +0,00	+0,040 +0,020	+0,060 +0,030
13BB1	SBB0 1301	16	13	3,5	6	24,75	h8	40	13 UNI	0,097	+0,11 +0,00	+0,040 +0,020	+0,060 +0,030
16BB	SBB0 1600	20	16	4	6	27,75	h8	40	16 UNI	0,108	+0,13 +0,00	+0,040 +0,020	+0,060 +0,030
18BB	SBB0 1800	22	18	5	6	31,75	h8	40	18 UNI	0,146	+0,13 +0,00	+0,040 +0,020	+0,060 +0,030
21BB	SBB0 2100	25	21	5	6	35,75	h8	45	21 UNI	0,208	+0,13 +0,00	+0,040 +0,020	+0,060 +0,030
23BB	SBB0 2300	28	23	6	6	39,70	h8	45	23 UNI	0,254	+0,13 +0,00	+0,040 +0,020	+0,060 +0,030
26BB	SBB0 2600	32	26	6	6	44,70	h8	45	26 UNI	0,322	+0,16 +0,00	+0,040 +0,020	+0,060 +0,030
32BB	SBB0 3200	38	32	6	8	49,70	h8	50	32 UNI	0,380	+0,16 +0,00	+0,040 +0,020	+0,060 +0,030
36BB	SBB0 3600	42	36	7	8	59,70	h8	70	36 UNI	0,880	+0,16 +0,00	+0,040 +0,020	+0,076 +0,040
42BB	SBB0 4200	48	42	8	8	69,70	h8	80	42 UNI	1,380	+0,16 +0,00	+0,040 +0,020	+0,076 +0,040
46BB	SBB0 4600	54	46	9	8	81,70	h8	90	46 UNI	2,324	+0,19 +0,00	+0,040 +0,020	+0,076 +0,040





GIUNTI CARDANICI <<MF>> IN ACCIAIO INOSSIDABILE SERIE <<X>> - DIN 808

I giunti della serie <<X>> sono costruiti interamente in acciaio inossidabile AISI 304 (norme internazionali X5CrNi18-10 N. 1.4301) nella versione standard.

Oppure, a richiesta:

- in acciaio inossidabile AISI 303
(norme internazionali X8CrNiS18-9 N. 1.4305)

- in acciaio inossidabile AISI 316
(norme internazionali X5CrNiMo17-12-2 N. 1.4401).

Tutti sono composti da due semigiunti terminanti a forcella ed un nucleo centrale a crociera. La principale caratteristica di resistenza alla corrosione dell'acciaio inossidabile rende i giunti serie <<X>> particolarmente idonei agli impieghi in ambienti aggressivi (industria chimica, alimentare, farmaceutica ed applicazioni marine), inoltre hanno buona resistenza al calore, alta tenacità a basse temperature e sono amagnetici. L'angolo di lavoro massimo è di 45° e 90° rispettivamente per i giunti a snodo singolo e doppio.

Vengono prodotte interamente in acciaio inossidabile anche le trasmissioni allungabili.

<<MF>> STAINLESS STEEL UNIVERSAL JOINTS SERIE <<X>> TO DIN 808

<<X>> series universal joints are entirely made in stainless steel AISI 304 standard execution (international standards X5CrNi18-10 N. 1.4301),

*or in AISI 303
(international standards X8CrNiS18-9 N. 1.4305)
and AISI 316
(international standards X5CrNiMo17-12-2 N. 1.4401)
on request.*

They all consist of a star wheel core and 2 half-joints with fork ends.

The corrosion resistance is the main feature which make the <<X>> series joints suitable for aggressive environments (chemical industry, food industry, pharmaceutical industry and marine applications). These joints also have good heat resistance, high toughness at low temperature and they are nonmagnetic.

Maximum working angle is 45° for single joints and 90° for double joints.

The <<X>> series joints are also supplied in telescopic version entirely made in stainless steel.



GIUNTI SINGOLI IN ACCIAIO INOX

STAINLESS STEEL SINGLE JOINTS

serie «X»
series (DIN 808)

- Angolo max. 45°
Max angle 45°
- "Esecuzione innesto rapido, vedi pagina 11".
"Quick release execution, see page 11".
- "Esecuzione a morsetto tipo CL1 o CL2, vedi pagine 20 e 21".
"Clamping hub execution type CL1 or CL2, see pages 20 and 21".
- Esecuzioni speciali a richiesta.
Special executions on request.

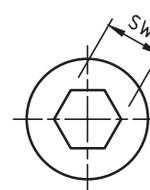
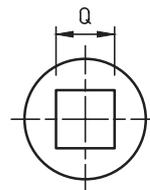
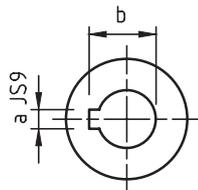
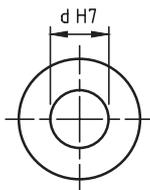
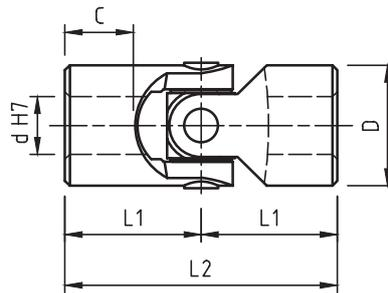

Mod. Type	Codice / Code	d	D	L2	L1	C	Codice / Code	a	b	Q *	SW *	Peso Weight Kg
01X	SX0S 0600	6	16	34	17	8	SX0S062C	2	7	6	6	0,05
02X	SX0S 0800	8	16	40	20	11	SX0S082C	2	9	8	8	0,05
03X	SX0S 1000	10	22	48	24	12	SX0S102C	3	11,4	10	10	0,10
04X	SX0S 1200	12	25	56	28	13	SX0S122C	4	13,8	12	12	0,16
1X	SX0S 1600	16	32	68	34	16	SX0S162C	5	18,3	16	16	0,30
3X	SX0S 2000	20	42	82	41	18	SX0S202C	6	22,8	20	20	0,60
5X	SX0S 2500	25	50	108	54	26	SX0S252C	8	28,3	25	25	1,20
6X	SX0S 3000	30	58	122	61	29	SX0S302C	8	33,3	30	30	1,85

*= Non sempre disponibile a magazzino / Not always available in stock



GIUNTI DOPPI IN ACCIAIO INOX

STAINLESS STEEL DOUBLE JOINTS

serie «X»
series (DIN 808)

- Angolo max. 90°
Max angle 90°
- "Esecuzione innesto rapido, vedi pagina 11".
"Quick release execution, see page 11".
- "Esecuzione a morsetto tipo CL1 o CL2, vedi pagine 20 e 21".
"Clamping hub execution type CL1 or CL2, see pages 20 and 21".
- Esecuzioni speciali a richiesta.
Special executions on request.

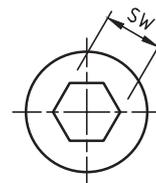
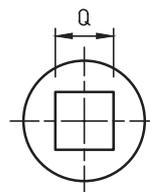
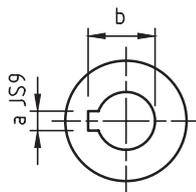
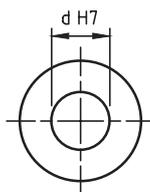
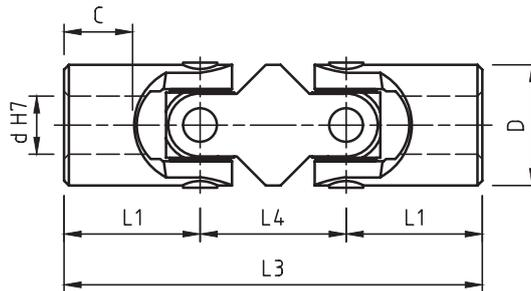

Mod. Type	Codice / Code	d	D	L3	L1	L4	C	Codice / Code	a	b	Q *	SW *	Peso Weight Kg
01XD	SX0D 0600	6	16	56	17	22	8	SX0D062C	2	7	6	6	0,08
02XD	SX0D 0800	8	16	62	20	22	11	SX0D082C	2	9	8	8	0,08
03XD	SX0D 1000	10	22	74	24	26	12	SX0D102C	3	11,4	10	10	0,15
04XD	SX0D 1200	12	25	86	28	30	13	SX0D122C	4	13,8	12	12	0,25
1XD	SX0D 1600	16	32	105	34	37	16	SX0D162C	5	18,3	16	16	0,45
3XD	SX0D 2000	20	42	129	41	47	18	SX0D202C	6	22,8	20	20	1,00
5XD	SX0D 2500	25	50	163	54	55	26	SX0D252C	8	28,3	25	25	2,00
6XD	SX0D 3000	30	58	190	61	68	29	SX0D302C	8	33,3	30	30	2,90

*= Non sempre disponibile a magazzino / Not always available in stock



TRASMISSIONI ALLUNGABILI IN ACCIAIO INOX

EXSTENSIBLE TRANSMISSIONS
IN STAINLESS STEEL

serie «X»
series (DIN 808)

- Lunghezza min. e max a richiesta:
Min. and max. lengths on request:

$$\frac{L. MIN.}{MIN. L.} > \frac{L. MAX. + 2 L2 + B}{2} \quad \frac{CORSA X}{STROKE X} < \frac{L. MAX. - 2 L2 - B}{2}$$

- “Esecuzione innesto rapido, vedi pagina 11”.
“Quick release execution, see page 11”.
- “Esecuzione a morsetto tipo CL1 o CL2, vedi pagine 20 e 21”.
“Clamping hub execution type CL1 or CL2, see pages 20 and 21”.
- Esecuzioni speciali a richiesta.
Special executions on request.

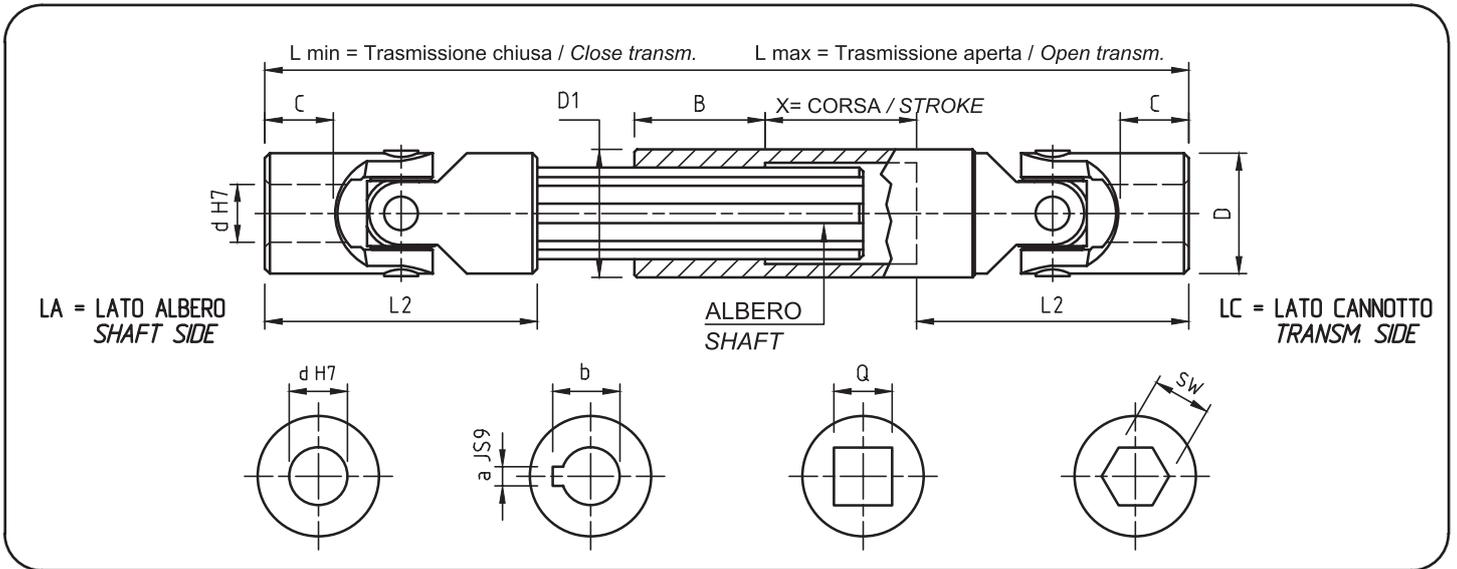

Mod. Type	d	D	L2	C	L min.	L max.	x	B	* a	* b	* Q	* SW	Albero Shaft	D1
					a richiesta - on request									
03XA	10	22	48	12	←	→	—	25	3	11,4	10	10	11 x 14 Z6	22
04XA	12	25	56	13	←	→	—	30	4	13,8	12	12	13 x 16 Z6	26
1XA	16	32	68	16	←	→	—	30	5	18,3	16	16	16 x 20 Z6	33
3XA	20	42	82	18	←	→	—	40	6	22,8	20	20	21 x 25 Z6	42
5XA	25	50	108	26	←	→	—	40	8	28,3	25	25	26 x 32 Z6	48
6XA	30	58	122	29	←	→	—	40	8	33,3	30	30	32 x 38 Z8	59

*= Non sempre disponibile a magazzino / Not always available in stock



ALBERI SCANALATI IN ACCIAIO INOX

SPLINED SHAFTS IN STAINLESS STEEL

serie «ASX»
series

- Materiale: Aisi 304 EN 1.4301
Material: Aisi 304 EN 1.4301
- Toll. rettilineità lineare max. 0,8mm/m - Toll. rettilineità torsionale max. 0,5mm/m.
Linear straightness tol. max. 0,8mm/m - Torsional straightness tol. max. 0,5mm/m.
- Lunghezza standard: 1 metro.
Stock length: 1 meter.
- Altre lunghezze a richiesta.
Other lengths on request.

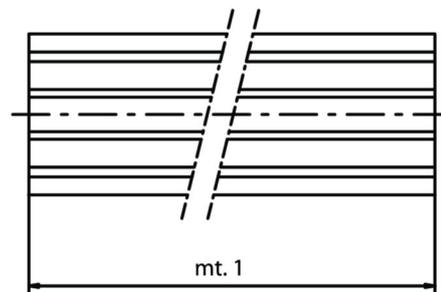
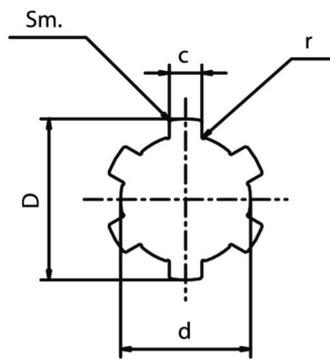

Mod. Type	Codice / Code	D	d	c	Z	Sez. / Section mm ²	Peso/Weight Kg/m	Tolleranze - Tolerances			Sm. 45°	r
								D	d	c		
11ASX	SASX 1100	14	11	3	6	121,9	0,949	-0,07 -0,20	0,00 -0,08	-0,03 -0,08	0,2	0,2
13ASX	SASX 1300	16	13	3,5	6	164,1	1,287	-0,07 -0,20	0,00 -0,08	-0,03 -0,08	0,2	0,2
16ASX	SASX 1600	20	16	4	6	243,4	1,911	-0,07 -0,25	0,00 -0,08	-0,03 -0,08	0,2	0,2
18ASX	SASX 1800	22	18	5	6	312,4	2,453	-0,07 -0,25	0,00 -0,08	-0,03 -0,08	0,2	0,2
21ASX	SASX 2100	25	21	5	6	399,8	3,139	-0,07 -0,27	0,00 -0,08	-0,03 -0,08	0,2	0,2
23ASX	SASX 2300	28	23	6	6	505,2	3,964	-0,07 -0,27	0,00 -0,08	-0,03 -0,08	0,3	0,2
26ASX	SASX 2600	32	26	6	6	638,6	5,008	-0,07 -0,27	0,00 -0,08	-0,03 -0,08	0,3	0,3
32ASX	SASX 3200	38	32	6	8	947,8	7,433	-0,07 -0,27	0,00 -0,08	-0,03 -0,08	0,3	0,3
36ASX	SASX 3600	42	36	7	8	1185,3	9,302	-0,07 -0,27	0,00 -0,08	-0,03 -0,08	0,3	0,3
42ASX	SASX 4200	48	42	8	8	1576,7	12,371	-0,07 -0,27	0,00 -0,08	-0,03 -0,08	0,3	0,3
46ASX	SASX 4600	54	46	9	8	1949	15,300	-0,07 -0,27	0,00 -0,08	-0,03 -0,08	0,5	0,5



BOCCOLE BROCCIATE IN ACCIAIO INOX

SPLINED BUSHES IN STAINLESS STEEL

serie «**BBX**»
series

- Materiale: Aisi 304 EN 1.4301
Material: Aisi 304 EN 1.4301
- Esecuzioni speciali a richiesta.
Special executions on request.

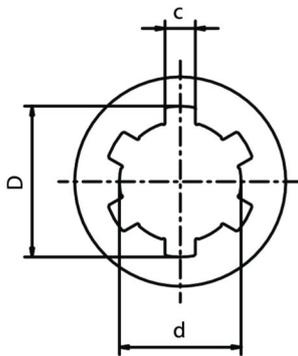

Mod. Type	Codice / Code	D	d	c	Z	Ø	TOLL.	L	Rif. uni Uni Ref.	Peso Weight Kg	Tolleranze - Tolerances		
											D (H11)	d (H7)	c (D9)
11BBX	SBBX 1100	14	11	3	6	18,75	h8	25	11 UNI	0,028	+0,11 +0,00	+0,018 +0,00	+0,045 +0,020
13BBX	SBBX 1300	16	13	3,5	6	21,75	h8	30	13 UNI	0,047	+0,11 +0,00	+0,018 +0,00	+0,060 +0,030
16BBX	SBBX 1600	20	16	4	6	28,50	h8	30	16 UNI	0,090	+0,13 +0,00	+0,018 +0,00	+0,060 +0,030
21BBX	SBBX 2100	25	21	5	6	36,00	h8	40	21 UNI	0,190	+0,13 +0,00	+0,021 +0,00	+0,060 +0,030
26BBX	SBBX 2600	32	26	6	6	42,50	h8	40	26 UNI	0,242	+0,16 +0,00	+0,021 +0,00	+0,060 +0,030
32BBX	SBBX 3200	38	32	6	8	49,70	h8	40	32 UNI	0,304	+0,19 +0,00	+0,025 +0,00	+0,060 +0,030



MANICOTTI DI PROTEZIONE

PROTECTION MUFFS

serie «M»
series

- Gomma speciale al neoprene.
Special neoprene rubber.
- Resistenti a: acidi, oli, grassi, polvere, umidità.
Resistant to: acids, oils, greases, dust, moisture.
- Riempiti di grasso, assicurano una costante lubrificazione.
Filled with grease, they ensure constant lubrication.

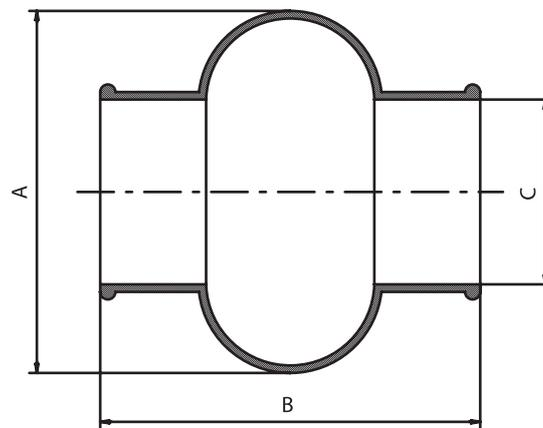

Mod. Type	Codice / Code	A	B	C	Diam. est. Giunti Joints out diam. "D"
01M	SM00 1600	28	34	15	16
02M	SM00 1800	32	40	16,5	18
03M	SM00 2200	40	45	20,5	22
04M	SM00 2500	48	50	24,5	25/26
05M	SM00 2800	52	56	27,5	28/29
1M	SM00 3200	56	65	30,5	32
2M	SM00 3600	66	72	35,5	36/37
3M	SM00 4200	75	82	40	42
4M	SM00 4500	84	95	45	45/47
5M	SM00 5000	92	108	50	50/52
6M	SM00 5800	100	122	56	58



CRITERI DI SCELTA

L' applicazione del giunto a snodo singolo a due alberi formanti un angolo (di cui quello movente ruoti a velocità costante) dà luogo ad una variazione periodica dell' albero comandato e precisamente a quattro fluttuazioni per giro.

Lo scarto, ossia la differenza di velocità massima e minima dell'albero condotto, è in funzione dell'angolo formato dai due alberi. La difformità cresce con l'aumentare dell'angolo α° .

Per rendere la trasmissione omocinetica si impiegano due giunti a snodo singolo contrapposti (tenendo presente che le due forcelle centrali devono risultare complanari e gli angoli dei due giunti uguali), oppure un giunto a snodo doppio.

L'irregolarità prodotta dalla prima articolazione viene annullata dalla seconda. La lunghezza di ingombro dovuta all'accoppiamento di due giunti singoli è ridotta ulteriormente, impiegando il giunto doppio. In altri termini, il giunto doppio è da considerarsi la trasmissione omocinetica più corta in assoluto.

Per applicazioni a bassi regimi di rotazione (Max. 1000/min.) si consiglia l'impiego di giunti con cuscinetti pieni a strisciamento (Mod. S, G/GB). Hanno la capacità di sopportare carichi d'urto, funzionamenti discontinui e momenti torcenti relativamente elevati.

Si tenga presente che l'angolo di lavoro deve essere contenuto a partire dai 500 fino ai 1000 giri/min.

Per velocità di rotazione elevate, momenti torcenti relativamente bassi, inversioni di moto o angoli rilevanti, si consiglia l'utilizzo dei giunti con cuscinetti a rullini (mod. H).

Possono raggiungere i 4000 giri/min. sempre in funzione dell'angolo.

LETTURA DEI DIAGRAMMI

La capacità di un giunto di trasmettere una certa coppia regolare ad un carico costante e senza urti, per un periodo di tempo più o meno lungo, dipende essenzialmente dal numero di giri al minuto primo e dall'angolo α° di inclinazione dei due assi. In base a questo criterio sono stati concepiti i diagrammi riportati nelle pag. 40 - 41.

Ogni curva corrisponde alla grandezza di un giunto con riferimento al diametro «D» esterno del mozzo e rappresenta la coppia trasmissibile dipendente dalla velocità e dall'angolo di lavoro α° .

I diagrammi possono essere letti direttamente con angolo $\alpha^\circ=10^\circ$.

Per angoli superiori, le coppie trasferibili diminuiscono, pertanto vanno corrette utilizzando i valori (F) relativi all'angolo, riportati nella tabella.

N.B.: I diagrammi riportano valori puramente indicativi, elaborati dalla MARIO FERRI s.r.l. e riferiti all'impiego di giunti singoli. Per quanto riguarda la scelta di un giunto doppio, si consideri che la coppia trasmissibile è inferiore a quella del giunto singolo di pari diametro esterno, nella misura di circa il 10%. Ogni applicazione ha caratteristiche di moto particolari, quali carichi d'urto, inversioni di moto, masse collegate, tipo di avviamento, presenza di giunti elastici, partenze e fermate, ecc., che l'utilizzatore dovrà considerare nell'effettuare la scelta.

SELECTING CRITERIA

When we couple one single joint with two shafts (of which the driving one is rotating at a constant speed) forming an angle, we cause a periodic variation of the driven shaft, exactly four fluctuations per revolution.

The difference between the maximum and the minimum speed of the driven shaft depends on the angle formed by the two shafts. The difference grows with the increasing of the angle α° .

To have a homokinetic transmission, you have to fit either two opposite single joints (paying attention that the two central yokes lie on the same plane and the angles are equal) or a double joint.

The irregularity caused by the former articulation is cancelled by the latter. The overall length resulting from the coupling of the two single joints is even more reduced using a double joint. In other words, the double joint is to be considered as the shortest homokinetic transmission.

For low speed applications (Max 1000 R.P.M.) joints with plain bearings (rubbing bearings) are suggested: types S, G/GB. They are able to support shock loads, irregular runnings and relatively high torques. The working angles must be kept between 500 and 1000 R.P.M.

For high rotation speeds, relatively low torques, motion reversals or wide angles, joints with needle roller bearings (type H) are to be preferred. They can reach 4000 R.P.M. always relating to the angle.

HOW TO READ DIAGRAMS

The joint capacity to transmit a regular torque at a constant load with no shocks, for a more or less long period, mainly depends on the number of revolutions per minute and the inclination angle α° of the two axes.

The diagrams on pages 40 - 41 have been conceived on the base of this criterium.

Each curve corresponds to the joint size (outside diameter «D») and represents the torque that the joint can transmit depending on speed and working angle α° .

The diagrams can be directly read if angle (α°) is 10° . For wider angles, torques are reduced, therefore these are to be corrected using the correction values (F) relating to the angle shown in the table.

IMPORTANT: *Diagrams' values are merely indicative, processed by MARIO FERRI s.r.l. and are referred to the single joints only. When choosing a double joint, you have to consider that this one can transmit a torque about 10% lower than the same sized single joints. Each application has its own particular motion characteristics, such as: shock loads, motion reversals, connected masses, kind of starting, presence of elastic joints, stops and starts, etc., that have to be considered by the user when choosing the joint.*



DIAGRAMMA PER GIUNTI

DIAGRAM FOR JOINTS

serie «S-G»
series

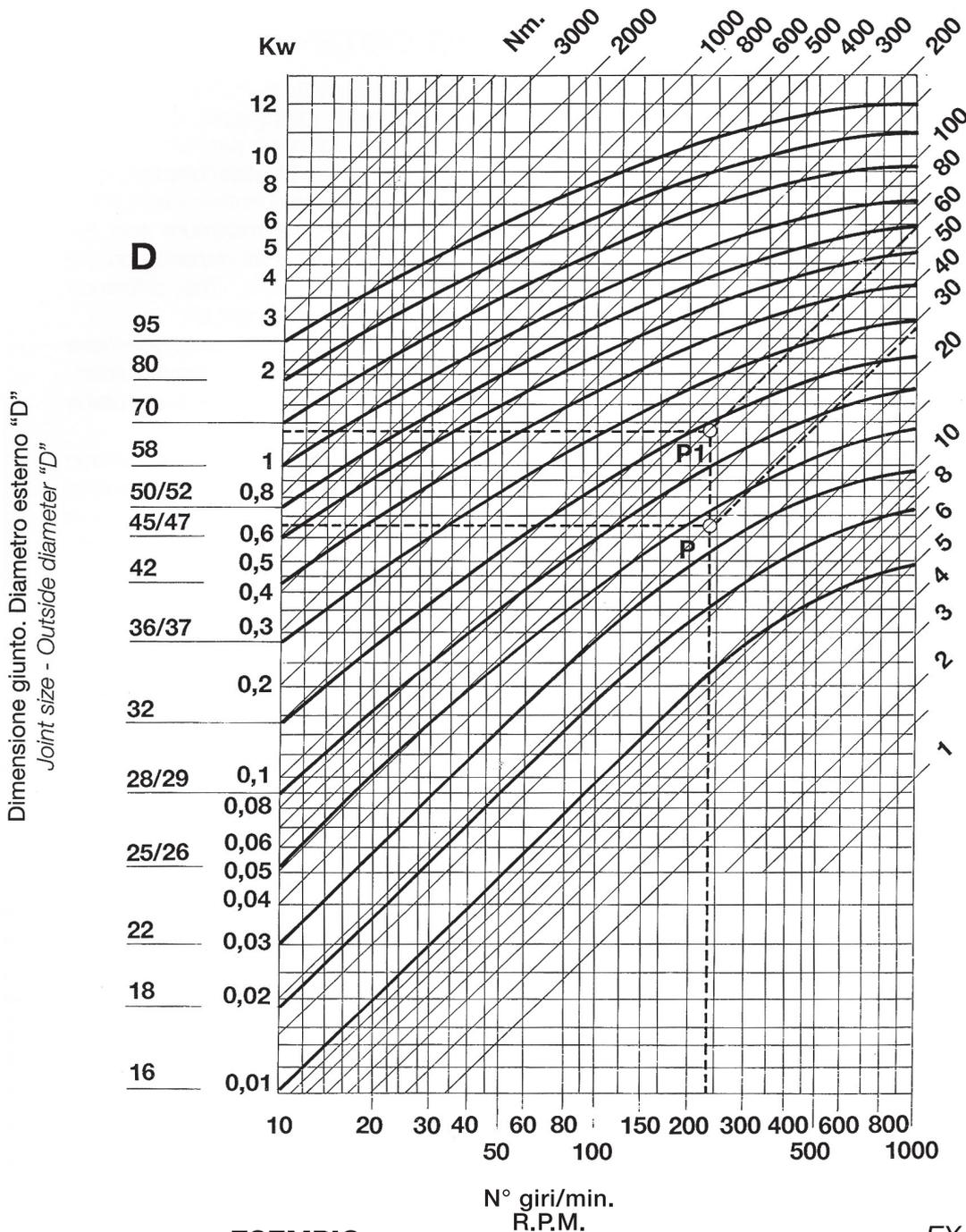

Momento torcente Mt. in Nm
Torque in Nm

45°	0,25
40°	0,30
35°	0,38
30°	0,45
25°	0,55
20°	0,65
15°	0,80
10°	1,00
5°	1,25
ANGOLO DI LAVORO «α» WORKING ANGLE «α»	VALORE DI CORREZIONE «F» CORRECTION VALUE «F»

ESEMPIO

- Potenza: 0,65 KW
- N° giri/min.: 230
- Con angolo di lavoro α 10° Valore F=1 si ottiene il punto P Mt = 27 Nm corrispondente alla grandezza del giunto «D» = 25/26 mm. = Mod. 04S, 04G, 1GB.
- Con angolo di lavoro α 30° Valore F=0,45 (Kw 0,65 : 0,45 = 1,44 Kw) si ottiene il punto P1 Mt = 60 Nm corrispondente alla grandezza del giunto «D» = 32 mm. = Mod. 1S, 1G, 3GB.

Si consideri che:

$$\text{Mt. in Nm} = 9550 \times \frac{N \text{ (KW)}}{n^\circ \text{ (Giri/min.)}}$$

$$\text{Mt. in Nm} = 7020 \times \frac{N \text{ (HP)}}{n^\circ \text{ (Giri/min.)}}$$

EXAMPLE

- Power: 0.65 KW
- R.P.M.: 230
- With working angle α 10° Value F=1 we get point P. Torque = 27 Nm corresponding to joint size «D» = 25/26 mm. = Types 04S, 04G, 1GB.
- With working angle α 30° Value F= 0.45 (Kw 0.65 : 0.45 = 1.44 Kw) we get point P1 Torque = 60 Nm corresponding to joint size «D» = 32 mm. = Types 1S, 1G, 3GB.

Consider that:

$$\text{Torque in Nm} = 9550 \times \frac{\text{Power (KW)}}{\text{R.P.M.}}$$

$$\text{Torque in Nm} = 7020 \times \frac{\text{Power (HP)}}{\text{R.P.M.}}$$

N° 1 KW = 1,35 HP - N° 1 HP = 0,736 KW
N° 1Kgm = 9,81 Nm - N° 1 Nm = 0,102 Kgm



DIAGRAMMA PER GIUNTI

DIAGRAM FOR JOINTS

serie «H»
series

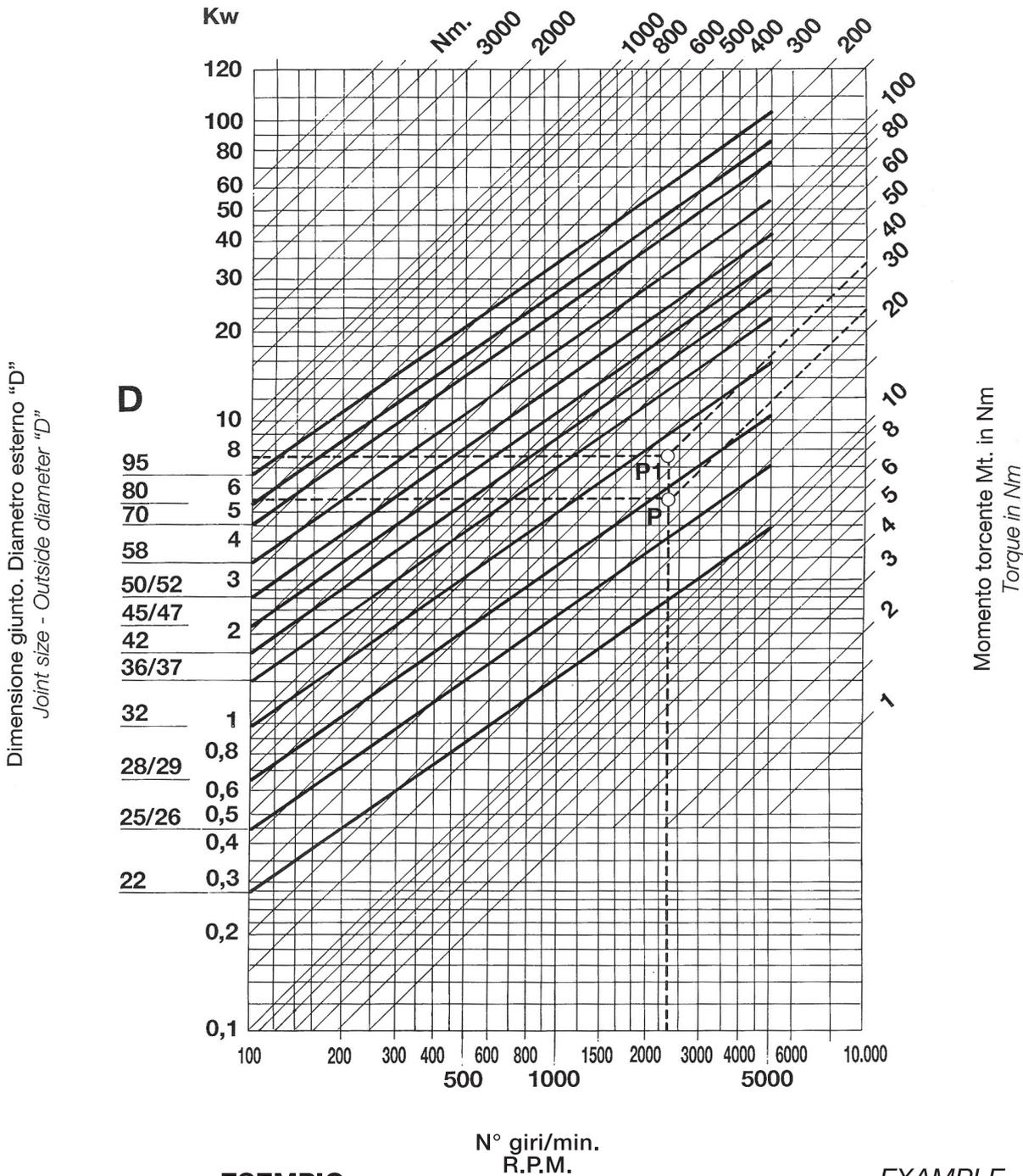

45°	0,25
40°	0,30
35°	0,40
30°	0,50
25°	0,70
20°	0,80
15°	0,90
10°	1,00
5°	1,25
ANGOLO DI LAVORO «α» WORKING ANGLE «α»	VALORE DI CORREZIONE «F» CORRECTION VALUE «F»

ESEMPIO

N° giri/min.
R.P.M.

EXAMPLE

- Potenza: 5,5 KW
- N° giri/min.: 2300
- Con angolo di lavoro α 10° Valore F=1 si ottiene il punto P Mt = 23 Nm corrispondente alla grandezza del giunto «D» = 28/29 mm. = Mod. 05H.
- Con angolo di lavoro α 25° Valore F= 0,70 (Kw 5,5 : 0,70 = 7,85 Kw) si ottiene il punto P1 Mt = 33 Nm corrispondente alla grandezza del giunto «D» = 32 mm. = Mod. 1H, 3HB.

Si consideri che:

$$\text{Mt. in Nm} = 9550 \times \frac{N \text{ (KW)}}{n^\circ \text{ (Giri/min.)}}$$

$$\text{Mt. in Nm} = 7020 \times \frac{N \text{ (HP)}}{n^\circ \text{ (Giri/min.)}}$$

- Power: 5.5 KW
- R.P.M.: 2300
- With working angle α 10° Value F=1 we get point P. Torque = 23 Nm corresponding to joint size «D» = 28/29 mm. = Types 05H.
- With working angle α 25° Value F= 0.70 (Kw 5.5 : 0.70 = 7.85 Kw) we get point P1 Torque = 33 Nm corresponding to joint size «D» = 32 mm. = Types 1H, 3HB.

Consider that:

$$\text{Torque in Nm} = 9550 \times \frac{\text{Power (KW)}}{\text{R.P.M.}}$$

$$\text{Torque in Nm} = 7020 \times \frac{\text{Power (HP)}}{\text{R.P.M.}}$$

N° 1 KW = 1,35 HP - N° 1 HP = 0,736 KW
N° 1Kgm = 9,81 Nm - N° 1 Nm = 0,102 Kgm

ISTRUZIONI PER UN CORRETTO MONTAGGIO
INSTRUCTION FOR A CORRECT FITTING UP

FIGURA 1
PICTURE 1



FIGURA 2
PICTURE 2



- a) Per ottenere un moto rotatorio uniforme impiegare sempre due giunti singoli contrapposti oppure un giunto a snodo doppio.
 I supporti degli alberi vanno posizionati il piu' vicino possibile ai giunti (vedi FIGURE 1 e 2).
*To obtain a uniform rotary motion always use either two opposite single joints or one double joint.
 The pillow blocks are to be positioned as close as possible to the joints (see PICTURES 1 and 2).*

FIGURA 3
PICTURE 3

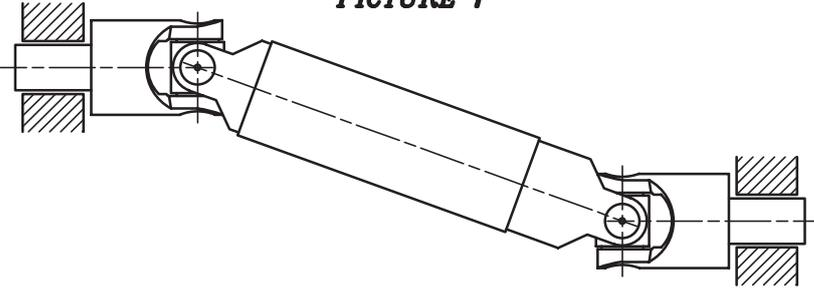
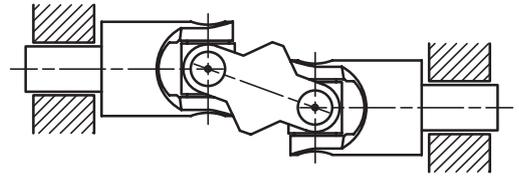

FIGURA 4
PICTURE 4



- b) Impiegando due giunti singoli contrapposti rispettare l'allineamento delle forcelle interne. Negli alberi allungabili osservare inoltre che le linee stampigliate combacino (vedi FIGURA 3 CORRETTO, FIGURA 4 ERRATO).
When using two opposite single joints respect the alignment of the inside yokes. In extensible transmissions also pay attention that the little lines stamped tally (see PICTURE 3 CORRECT, PICTURE 4 WRONG).

FIGURA 5
PICTURE 5

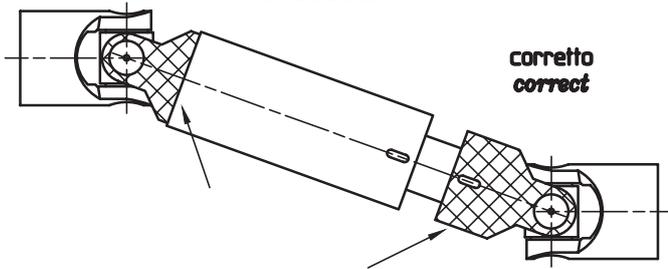
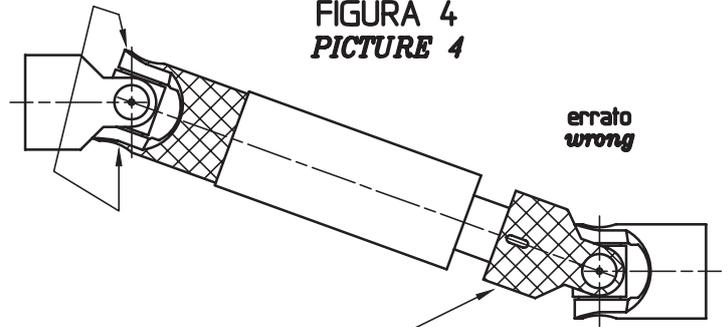
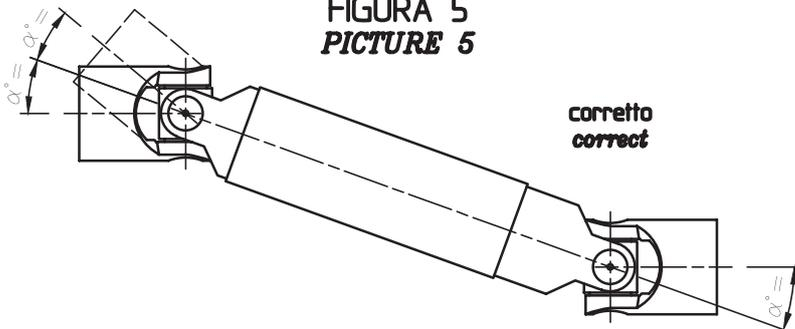

- c) Gli angoli di articolazione α° devono essere uguali (vedi FIGURA 5).
 Gli angoli possono spostarsi tra fra di loro solo parallelamente oppure simmetricamente.
*The joint angles α° must be equal (see PICTURE 5).
 The shafts can only be moved one from the other either parallelly or symmetrically.*



Sede principale di MARIO FERRI srl in via G. Miglioli n. 2 a Castelleone (CR) Italy



Distaccamento produttivo di MARIO FERRI srl in via G. Miglioli n. 25 a Castelleone (CR) Italy



MARIO FERRI s.r.l. - *Universal Joints*
26012 CASTELLEONE (CR) ITALIA
Viale Guido Miglioli, 2 - Tel. +39 0374 56450
www.marioferri.com e-mail: info@marioferri.com