

# TAKTOMAT

passion for automation

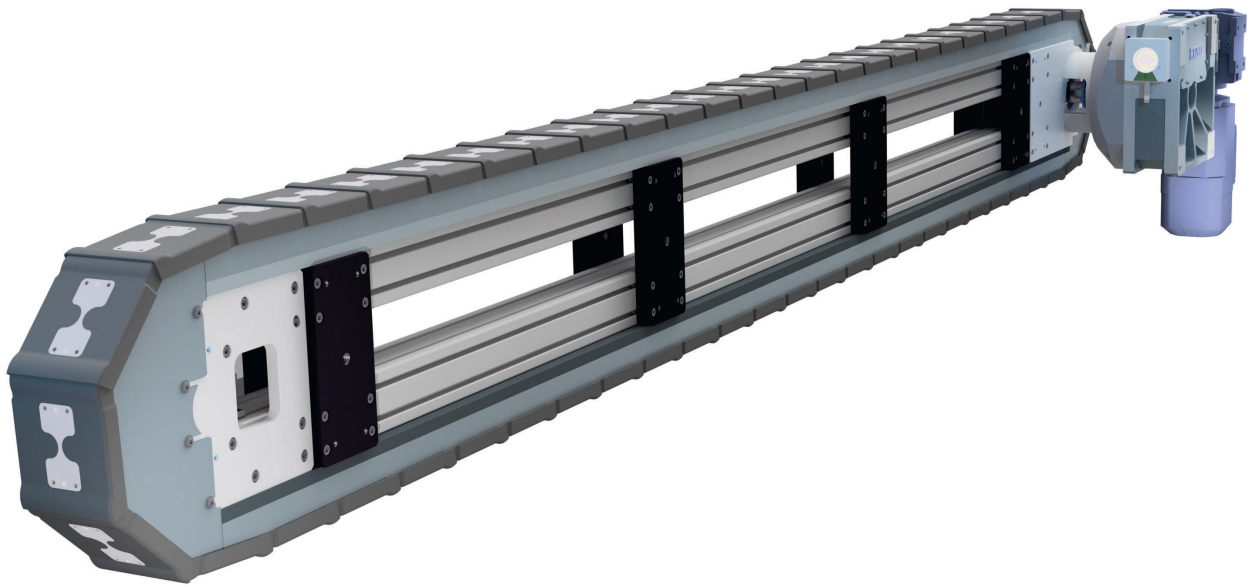

## Fast linear transfer system

Type LFA

## TAKTOMAT – Your specialist for automation

TAKTOMAT is your reliable partner for industrial automation and responds to the challenges of multiple industries with customised solutions. Since almost 30 years the TAKTOMAT GmbH produces precise, customer-oriented and high-quality products and solutions for the automation industry e. g. bevel gear, rotary tables, rotary indexers, parallel gears or cam mechanism.

This long-standing experience and customer focus makes the company to one of the world's leading manufacturer of handling and drive technology. Approximately 100 employees daily create ideal to the needs of customers' adapted products. Because of that TAKTOMAT products not only convince through innovation, but also with first-class quality.

### Customer orientation

TAKTOMAT is flexible and highly individual, since it focuses on its own strengths. Fast internal processes ensure the shortest delivery times. Thanks to optimised organisational and process structures and its large parts warehouse, TAKTOMAT is able to considerably shorten delivery times. Consistent customer orientation as our corporate philosophy is the key to our success.

### Variety

TAKTOMAT offers a wide product portfolio based on all the drive systems currently available on the market: barrel cams, disk cams, globoidal cams and servo technology. Naturally, TAKTOMAT also designs individual drive solutions that are not included in its catalogue program, so that customers can always access optimum solutions from a single source.

### Quality assurance

Thanks to our 100 percent parts monitoring, all components produced by TAKTOMAT meet the highest requirements for consistent quality and precision. All these components are manufactured in-house. TAKTOMAT is certified in accordance with DIN EN ISO 9001 2000 (since 2001). With the maintenance-free "TAKTOMAT hardening quality" at fair prices, we are making great strides in terms of precision and reliability on the market. Long-term load tests and satisfied customers are proof of this.

### Competitive edge

TAKTOMAT is committed to achieving the technologically feasible through continuous research projects and many years of experience with vehicle manufacturers. The integration of research and science in the development process, the continual optimisation of quality and the patents for TAKTOMAT's in-house developments all exemplify the innovative power of the company. Our partner Motion Index Drives has experience in the USA with rotary indexing tables and rotary barrel drives dating back to 1970.

### Presence

Through a strong international focus and an extensive network of sales offices, TAKTOMAT goes the extra mile to meet its customers. The TAKTOMAT field service has sound technical knowledge and is the "first developer" for our customers. Alongside valuable experience and a highly motivated team, TAKTOMAT also has the necessary drive to spur projects on and ensure they are completed quickly. That is why our commitment is reflected in our slogan and company culture: passion for automation.

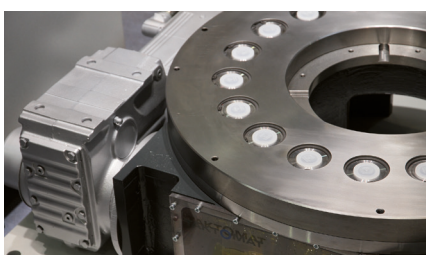

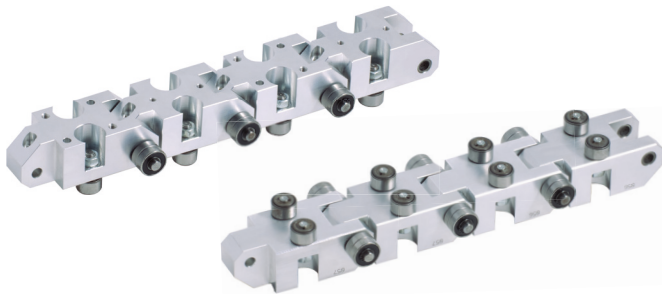
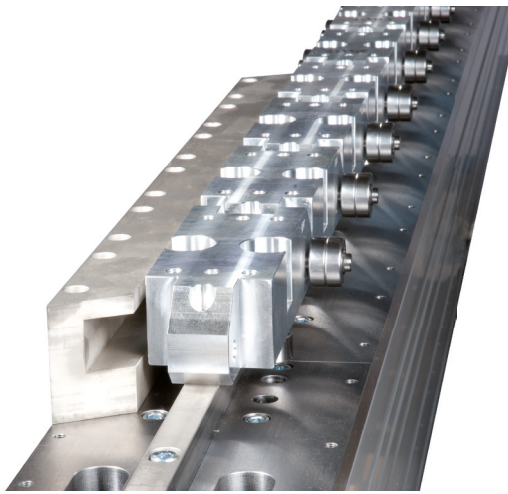

The sky is the limit for the TAKTOMAT product line. Flexible, made-to-order custom designs which are not featured in the product catalog have long been embedded in our corporate philosophy. We keep 10% of our entire workforce in reserve for these custom applications. Our skilled staff are available to assist our customers on a daily basis.

Our drives meet the highest standards regarding quality and precision. Our cams are manufactured in a different manner with regards to our competition, therefore it is often possible to use smaller rotary table sizes supplied by TAKTOMAT instead of larger ones supplied by our competitors.

Our extensive design expertise enables us to meet customer requirements down to the last detail. We can combine the advantages of different forms of drives to create new value-added solutions which fit the bill completely. This is the added value which we have been offering to our customers in different sectors for many years.

## Main fields

Assembly Industry, Medical Technology, Cosmetics, Electronic Industry

- Fast assembly of small parts - up to 150 cycles per minute
- Transportation and manufacturing of wires or similar parts
- Mechanical and optical investigations
- Welding, Tumbling, Riveting, Bending, Marking, Filling ...

## Precision Link Conveyor LFA – design and mode of operation

The main component is a continuous chain manufactured from highly precise aluminum links. Per link four cam followers for the vertical guidance roll by a hardened and fine-milled guide rail. Two ball bearings provide at a hard bar for the horizontal adjustment. The links are connected by bolts and needle bearings.

The main frame is made from aluminum profile and steel plates. The conveyor can be mounted at the aluminum profile or at the steel plates. Additional external stations can also be fixed there.

The chain is moved by a hardened step wheel, driven by a standard indexer or any other custom specified drive. At the other end a hard 180° cam guides the chain. This cam is preloaded, so there is no backlash at the links. The linear stroke of the chain depends on the diameter of the step wheel. One cycle of the indexer means a linear stroke of one, two or three links.

### Advantages for design engineers and special machine builders

- Proven reliable though many years of series
- Vertical assembly - saves room. The empty carriers travel through the bottom of the machine
- Horizontal assembly - in an oval formation. Both sides of the machine can be used for assembly
- The free drive shaft of the indexer can be used for a synchronously rotating parallel shaft to drive other units
- The aluminum profile system can be used to mount other external stations fast and easily

### Allowance for individual customer requirements

- Custom specified drives are available
- Optional overload protection
- Dwell- and index angle can be customized in a large range
- Non standard links and linear strokes are possible
- The chain can be designed in metric or english
- Customized color without additional cost
- Stainless steel, nickel plating or other special surfaces are available

### Technical benefits for users

- High reliability and long lifetime
- Robust method of construction
- Proven to last many years
- Needle or ball bearings rolling in oil bath or on clean, dry and hard surfaces
- Low maintenance (only once a year check and adjust the preloading of the chain)
- Wear-free by using TIC (Taktomat Indexing Controller)

# LFA080

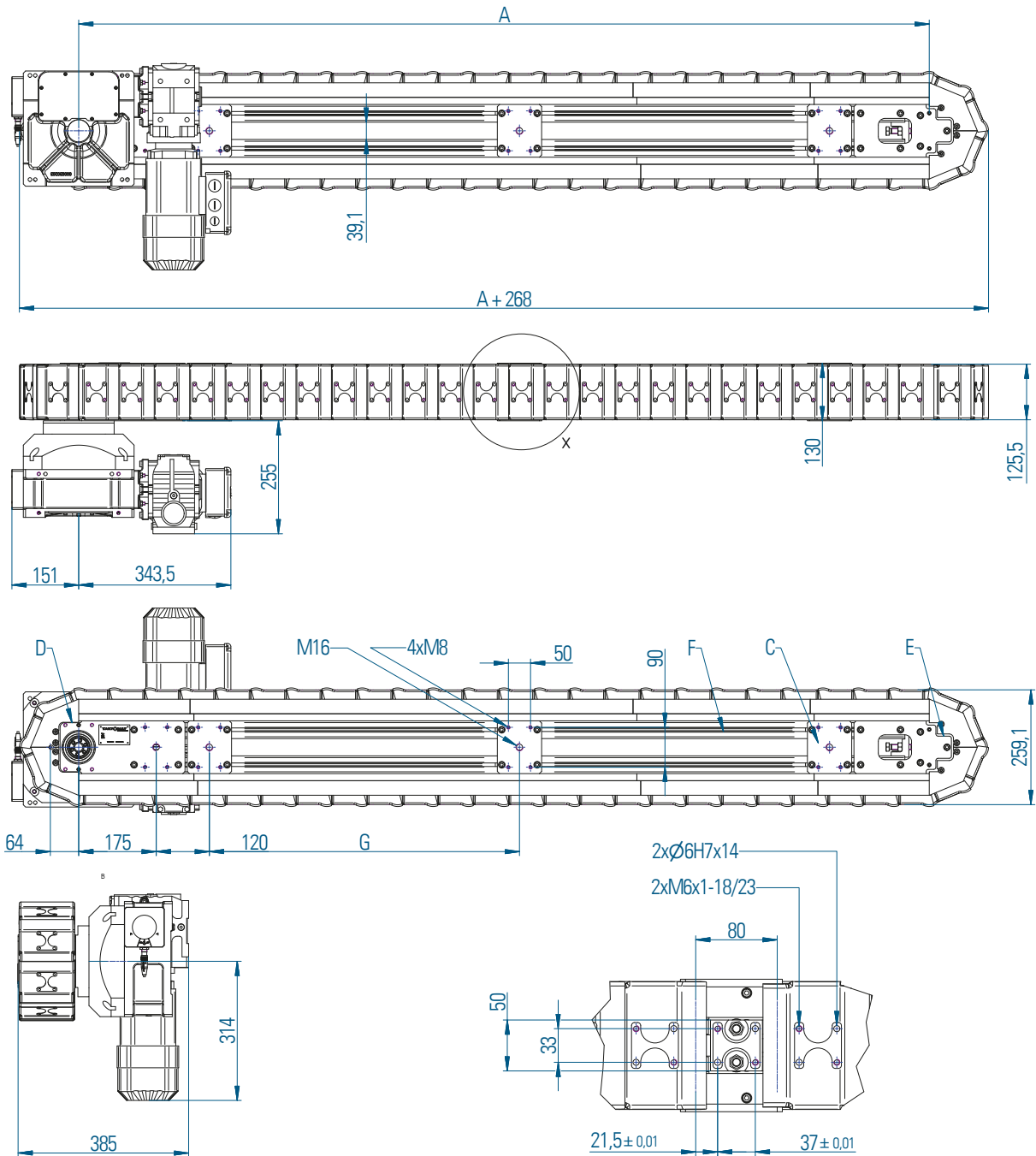

## Dimensions

The dimensions shown here are the standard dimensions. Dimension „A“ depends on the number of links. TAKTOMAT LFA Conveyors can either be mounted on the extruded aluminum „F“ or on the steel plates „C“. The links and the steel plates can be machined to your specifications.

The dimensions marked with \* depend on the size of the used drive. The conveyor can be delivered without drive or the drive can be a servo. Special dust covers or rubber lips between the links are available.

**⚠ Caution!** Allow spacs on side of the index wheel for adjusting the preload!

A = Distance between U-Turns

D = Index wheel

E = The 180° cam

F = Aluminum Profile System 8-80x120

## Load Table LFA080

s [mm]	t [s]	$n_L = 12 ; n_T = 32$ A= 960mm				$n_L = 18 ; n_T = 44$ A= 1440mm				$n_L = 24 ; n_T = 56$ A= 1920mm				$n_L = 30 ; n_T = 68$ A= 2400mm				$n_L = 36 ; n_T = 80$ A= 2880mm			
		m [kg]				m [kg]				m [kg]				m [kg]				m [kg]			
		0,5	1	1,5	2	0,5	1	1,5	2	0,5	1	1,5	2	0,5	1	1,5	2	0,5	1	1,5	2
80 <sup>1)</sup>	t=	0,16	0,19	0,22	0,25	0,18	0,22	0,26	0,29	0,21	0,25	0,3	0,23	0,23	0,28	0,33	0,37	0,25	0,30	0,35	0,4
160 <sup>2)</sup>	t=	0,24	0,29	0,34	0,38	0,28	0,34	0,40	0,45	0,31	0,39	0,45	0,35	0,35	0,43	0,50	0,56	0,38	0,46	0,54	0,61
240 <sup>3)</sup>	t=	0,32	0,40	0,46	0,52	0,38	0,47	0,54	0,61	0,43	0,53	0,61	0,47	0,47	0,58	0,68	0,76	0,51	0,63	0,74	0,83
320 <sup>4)</sup>	t=	0,40	0,48	0,52	0,6	0,48	0,59	0,70	0,76	0,54	0,64	0,75	0,81	0,59	0,73	0,86	0,96	0,64	0,80	0,94	1,04

s [mm]	t [s]	$n_L = 42 ; n_T = 92$ A= 3360mm				$n_L = 48 ; n_T = 104$ A= 3840mm				$n_L = 54 ; n_T = 116$ A= 4320mm				$n_L = 60 ; n_T = 128$ A=4800mm				$n_L = 66 ; n_T = 140$ A=5280mm			
		m [kg]				m [kg]				m [kg]				m [kg]				m [kg]			
		0,5	1	1,5	2	0,5	1	1,5	2	0,5	1	1,5	2	0,5	1	1,5	2	0,5	1	1,5	2
80 <sup>1)</sup>	t=	0,27	0,33	0,38	0,43	0,28	0,35	0,41	0,46	0,60	0,37	0,43	0,49	0,31	0,39	0,45	0,51	0,33	0,41	0,48	0,54
160 <sup>2)</sup>	t=	0,40	0,50	0,58	0,66	0,43	0,53	0,62	0,70	0,45	0,56	0,66	0,74	0,48	0,59	0,69	0,78	0,50	0,62	0,73	0,82
240 <sup>3)</sup>	t=	0,55	0,68	0,79	0,90	0,59	0,73	0,85	0,96	0,62	0,77	0,90	1,01	0,65	0,81	0,95	1,07	0,68	0,85	0,99	1,12
320 <sup>4)</sup>	t=	0,70	0,86	1,00	1,14	0,76	0,93	1,08	1,16	0,79	0,98	1,14	1,21	0,83	1,01	1,19	1,25	0,87	1,04	1,24	1,30

\*\* Other distances „A“, strokes or stroke times on request

s = Stroke [mm]  
t = Stroke Time [s]

$n_L$  = Number of links in line  
 $n_T$  = Number of links total

m = Weight per link [kg]  
A = Distance between U-Turns

<sup>1)</sup> The chain moves one link with each index.

<sup>2)</sup> The chain moves two links with each index.

<sup>3)</sup> The chain moves three links with each index.

<sup>4)</sup> The chain moves four links with each index.

## Technical specifications

### Main dimensions

Distance** [mm]	in steps of 480
Weight at A=2000 [kg]	300
Stroke time** [s]	see Load Table
Stroke** [mm]	80, 160, 240 or 320
Direction	right, left

### Loadings

pro stehendem Kettenglied	
Kraft senkrecht [N]	700
Kraft quer [N]	2600
Kippmoment [Nm]	80
Zugkraft an Kette [N]	3000

### Precision

in feed direction*	
at the drive [mm]	±0,04
opposite the drive [mm]	±0,07
Transverse to feed direction [mm]	±0,05
vertical runout [mm]	±0,03

### Standard Drive

RT160 with 8<sup>1</sup>, 4<sup>2</sup>, 8/3<sup>3</sup> or 2 Indexes

\* for the first and the last link in line we can not guarantee this precision.

# LFA100

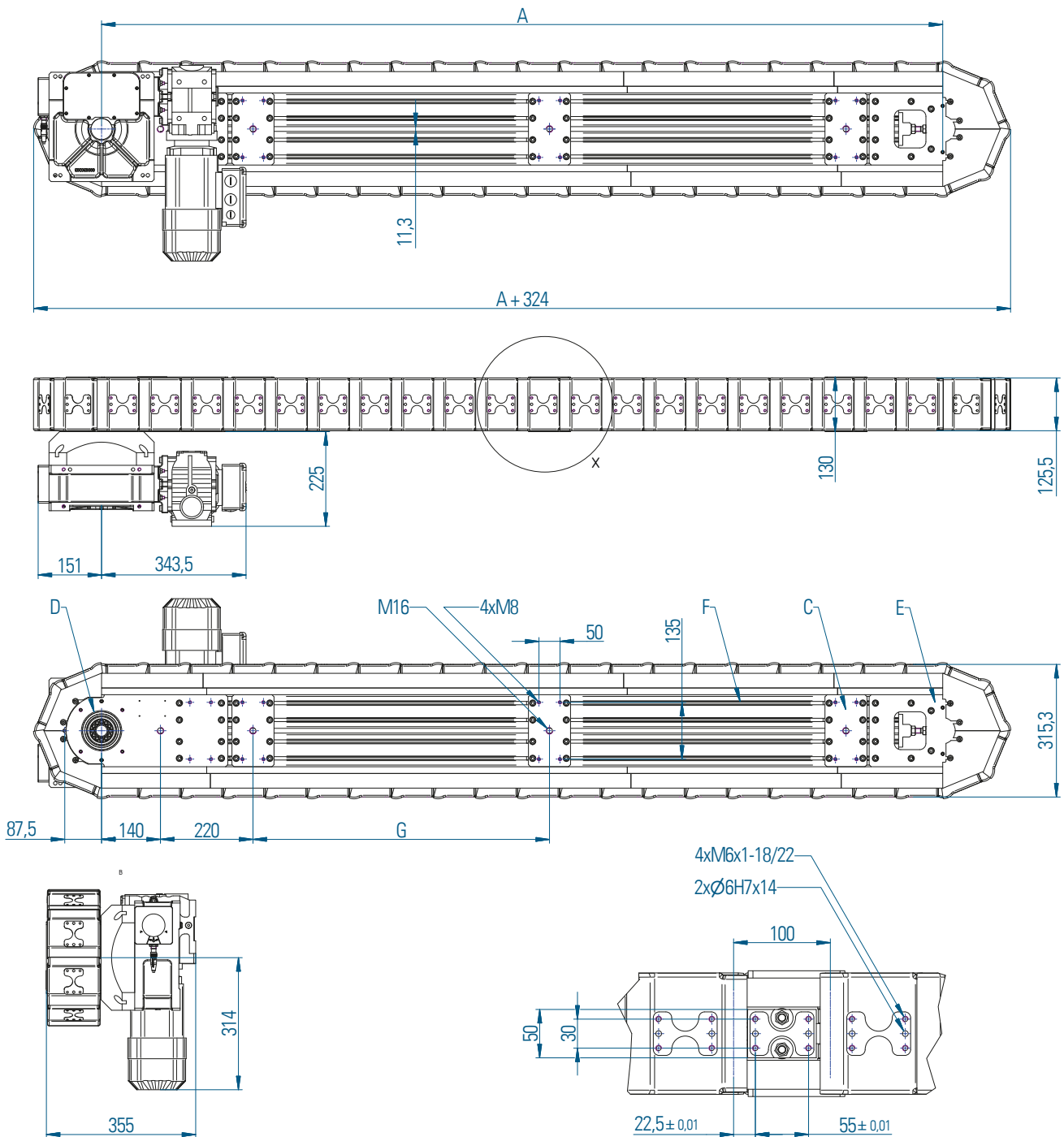

## Dimensions

The dimensions shown here are the standard dimensions. Dimension „A“ depends on the number of links. TAKTOMAT LFA Conveyors can either be mounted on the extruded aluminum „F“ or on the steel plates „C“. The links and the steel plates can be machined to your specifications.

The dimensions marked with \* depend on the size of the used drive. The conveyor can be delivered without drive or the drive can be a servo. Special dust covers or rubber lips between the links are available.

**⚠ Caution!** Allow spacs on side of the index wheel for adjusting the preload!

A = Distance between U-Turns

D = Index wheel

E = The 180° cam

F = Aluminum Profile System 2x 8-80x80

## Load Table LFA100

s [mm]	t [s]	$n_L = 10 ; n_T = 28$ A= 1000mm				$n_L = 15 ; n_T = 38$ A= 1500mm				$n_L = 20 ; n_T = 48$ A= 2000mm				$n_L = 25 ; n_T = 58$ A= 2500mm				$n_L = 30 ; n_T = 68$ A= 3000mm			
		m [kg]				m [kg]				m [kg]				m [kg]				m [kg]			
		0,5	1	1,5	2	0,5	1	1,5	2	0,5	1	1,5	2	0,5	1	1,5	2	0,5	1	1,5	2
100 <sup>1)</sup>	t=	0,16	0,19	0,22	0,24	0,18	0,22	0,26	0,29	0,21	0,25	0,29	0,32	0,23	0,28	0,32	0,36	0,25	0,30	0,34	0,39
200 <sup>2)</sup>	t=	0,24	0,29	0,33	0,37	0,28	0,34	0,39	0,44	0,31	0,38	0,44	0,49	0,35	0,42	0,48	0,54	0,38	0,46	0,52	0,59
300 <sup>3)</sup>	t=	0,33	0,40	0,46	0,51	0,38	0,46	0,53	0,60	0,43	0,52	0,60	0,67	0,47	0,57	0,66	0,74	0,51	0,62	0,72	0,80
400 <sup>4)</sup>	t=	0,40	0,51	0,59	0,65	0,45	0,57	0,68	0,74	0,50	0,63	0,75	0,81	0,55	0,68	0,81	0,89	0,60	0,73	0,87	0,95

s [mm]	t [s]	$n_L = 35 ; n_T = 78$ A= 3500mm				$n_L = 40 ; n_T = 88$ A= 4000mm				$n_L = 45 ; n_T = 98$ A= 4500mm				$n_L = 50 ; n_T = 108$ A=5000mm				$n_L = 55 ; n_T = 118$ A=5500mm			
		m [kg]				m [kg]				m [kg]				m [kg]				m [kg]			
		0,5	1	1,5	2	0,5	1	1,5	2	0,5	1	1,5	2	0,5	1	1,5	2	0,5	1	1,5	2
100 <sup>1)</sup>	t=	0,26	0,32	0,37	0,41	0,28	0,34	0,39	0,44	0,30	0,36	0,42	0,47	0,31	0,38	0,44	0,49	0,33	0,40	0,46	0,52
200 <sup>2)</sup>	t=	0,40	0,49	0,56	0,63	0,43	0,52	0,60	0,67	0,45	0,55	0,63	0,71	0,47	0,58	0,67	0,75	0,50	0,60	0,70	0,79
300 <sup>3)</sup>	t=	0,55	0,67	0,77	0,86	0,58	0,71	0,82	0,92	0,62	0,75	0,87	0,97	0,65	0,79	0,91	1,02	0,68	0,83	0,96	1,07
400 <sup>4)</sup>	t=	0,65	0,78	0,92	1,02	0,68	0,82	0,97	1,08	0,72	0,86	1,02	1,14	0,75	0,90	1,06	1,19	0,79	0,95	1,12	1,25

\*\* Other distances „A“, strokes or stroke times on request

s = Stroke [mm]  
t = Stroke Time [s]  
 $\alpha$  = Switching angle on the drive [°]

$n_L$  = Number of links in line  
 $n_T$  = Number of links total

m = Weight per link [kg]  
A = Distance between U-Turns

<sup>1)</sup> The chain moves one link with each index.

<sup>2)</sup> The chain moves two links with each index.

<sup>3)</sup> The chain moves three links with each index.

<sup>4)</sup> The chain moves four links with each index.

## Technical specifications

### Main dimensions

Distance** [mm]	in steps of 500
Weight at A=2000 [kg]	350
Stroke time** [s]	see Load Table
Stroke** [mm]	100, 200, 300 or 400
Direction	right, left

### Loadings

pro stehendem Kettenglied	
Kraft senkrecht [N]	700
Kraft quer [N]	2600
Kippmoment [Nm]	80
Zugkraft an Kette [N]	3000

### Precision

in feed direction*	
at the drive [mm]	±0,04
opposite the drive [mm]	±0,07
Transverse to feed direction [mm]	±0,05
vertical runout [mm]	±0,03

### Standard Drive

RT160 with 8<sup>1</sup>, 4<sup>2</sup>, 8/3<sup>3</sup> or 2 Indexes

\* for the first and the last link in line we can not guarantee this precision.

# LFA125

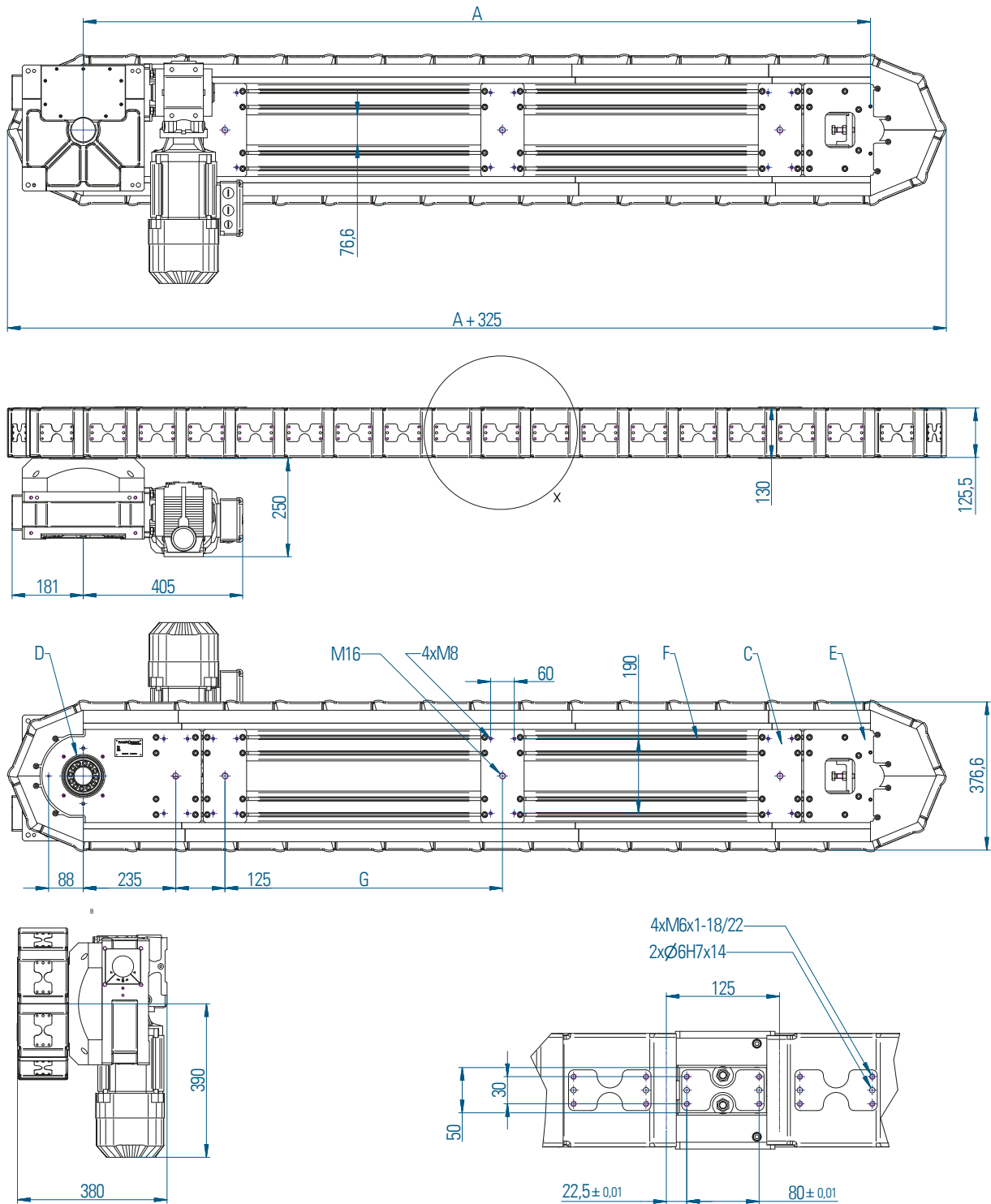

## Dimensions

The dimensions shown here are the standard dimensions. Dimension „A“ depends on the number of links. TAKTOMAT LFA Conveyors can either be mounted on the extruded aluminum „F“ or on the steel plates „C“. The links and the steel plates can be machined to your specifications. The dimensions

marked with \* depend on the size of the used drive. The conveyor can be delivered without drive or the drive can be a servo. Special dust covers or rubber lips between the links are available.

**⚠ Caution!** Allow spacs on side of the index wheel for adjusting the preload!

A = Distance between U-Turns

D = Index wheel

E = The 180° cam

F = Aluminum Profile System 8-80x120



## Load Table LFA125

s [mm]	t [s]	$n_L = 8 ; n_T = 24$ A= 1000mm				$n_L = 12 ; n_T = 32$ A= 1500mm				$n_L = 16 ; n_T = 40$ A= 2000mm				$n_L = 20 ; n_T = 48$ A= 2500mm				$n_L = 24 ; n_T = 56$ A= 3000mm			
		m [kg]				m [kg]				m [kg]				m [kg]				m [kg]			
		0,5	1	1,5	2	0,5	1	1,5	2	0,5	1	1,5	2	0,5	1	1,5	2	0,5	1	1,5	2
125 <sup>1)</sup>	t=	0,17	0,20	0,23	0,25	0,19	0,23	0,26	0,29	0,22	0,26	0,29	0,32	0,24	0,28	0,32	0,36	0,26	0,30	0,35	0,39
250 <sup>2)</sup>	t=	0,25	0,30	0,34	0,38	0,29	0,35	0,40	0,44	0,33	0,39	0,45	0,49	0,36	0,43	0,49	0,54	0,39	0,46	0,53	0,59
375 <sup>3)</sup>	t=	0,35	0,41	0,47	0,52	0,40	0,48	0,54	0,60	0,45	0,53	0,61	0,68	0,49	0,59	0,67	0,74	0,53	0,63	0,72	0,80
500 <sup>4)</sup>	t=	0,45	0,52	0,59	0,66	0,50	0,59	0,66	0,74	0,55	0,71	0,75	0,82	0,60	0,77	0,82	0,87	0,64	0,81	0,87	0,93

s [mm]	t [s]	$n_L = 28 ; n_T = 64$ A= 3500mm				$n_L = 32 ; n_T = 72$ A= 4000mm				$n_L = 36 ; n_T = 80$ A= 4500mm				$n_L = 40 ; n_T = 88$ A=5000mm				$n_L = 44 ; n_T = 96$ A=5500mm			
		m [kg]				m [kg]				m [kg]				m [kg]				m [kg]			
		0,5	1	1,5	2	0,5	1	1,5	2	0,5	1	1,5	2	0,5	1	1,5	2	0,5	1	1,5	2
125 <sup>1)</sup>	t=	0,27	0,33	0,37	0,41	0,29	0,35	0,40	0,44	0,31	0,37	0,42	0,46	0,32	0,38	0,44	0,49	0,34	0,40	0,46	0,51
250 <sup>2)</sup>	t=	0,42	0,50	0,57	0,63	0,44	0,53	0,60	0,67	0,47	0,56	0,64	0,71	0,49	0,58	0,67	0,74	0,51	0,61	0,70	0,78
375 <sup>3)</sup>	t=	0,57	0,68	0,77	0,86	0,60	0,72	0,82	0,92	0,64	0,76	0,87	0,97	0,67	0,80	0,91	1,02	0,70	0,83	0,95	1,06
500 <sup>4)</sup>	t=	0,69	0,86	0,93	1,00	0,72	0,91	0,98	1,06	0,76	0,95	1,04	1,11	0,80	1,00	1,09	1,15	0,84	1,03	1,13	1,19

\*\* Other distances „A“, strokes or stroke times on request

s = Stroke [mm]  
t = Stroke Time [s]  
 $\alpha$  = Switching angle on the drive [°]

$n_L$  = Number of links in line  
 $n_T$  = Number of links total

m = Weight per link [kg]  
A = Distance between U-Turns

<sup>1)</sup> The chain moves one link with each index.

<sup>2)</sup> The chain moves two links with each index.

<sup>3)</sup> The chain moves three links with each index.

<sup>4)</sup> The chain moves four links with each index.

## Technical specifications

### Main dimensions

Distance** [mm]	in steps of 500
Weight at A=2000 [kg]	400
Stroke time** [s]	see Load Table
Stroke** [mm]	125, 250, 375 or 500
Direction	right, left

### Loadings

pro stehendem Kettenglied	
Kraft senkrecht [N]	700
Kraft quer [N]	2600
Kippmoment [Nm]	80
Zugkraft an Kette [N]	3000

### Precision

in feed direction*	
at the drive [mm]	±0,04
opposite the drive [mm]	±0,07
Transverse to feed direction [mm]	±0,05
vertical runout [mm]	±0,03

### Standard Drive

RT160 with 8<sup>1</sup>, 4<sup>2</sup>, 8/3<sup>3</sup> or 2 Indexes

\* for the first and the last link in line we can not guarantee this precision.

# LFA150

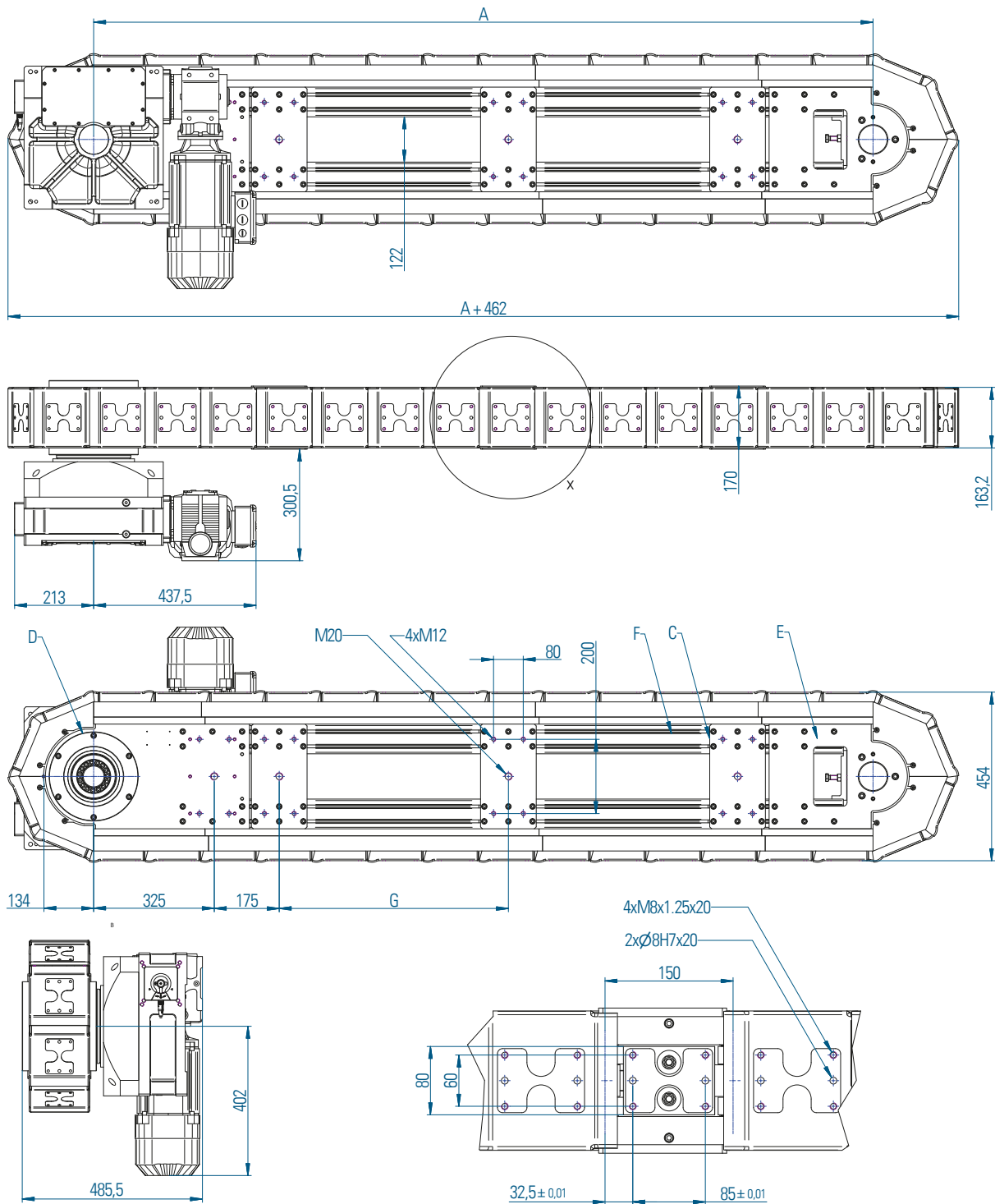

## Dimensions

The dimensions shown here are the standard dimensions. Dimension „A“ depends on the number of links. TAKTOMAT LFA Conveyors can either be mounted on the extruded aluminum „F“ or on the steel plates „C“. The links and the steel plates can be machined to your specifications. The dimensions

marked with \* depend on the size of the used drive. The conveyor can be delivered without drive or the drive can be a servo. Special dust covers or rubber lips between the links are available.

**⚠ Caution!** Allow spacs on side of the index wheel for adjusting the preload!

A = Distance between U-Turns

D = Index wheel

E = The 180° cam

F = Aluminum Profile System 8-80x120

## Load Table LFA150

s [mm]	t [s]	$n_L = 7 ; n_T = 22$ A= 1050mm				$n_L = 12 ; n_T = 32$ A= 1800mm				$n_L = 16 ; n_T = 40$ A= 2400mm				$n_L = 20 ; n_T = 48$ A= 3000mm				$n_L = 24 ; n_T = 56$ A= 3600mm			
		m [kg]				m [kg]				m [kg]				m [kg]				m [kg]			
		0,5	1	1,5	2	0,5	1	1,5	2	0,5	1	1,5	2	0,5	1	1,5	2	0,5	1	1,5	2
150 <sup>1)</sup>	t=	0,28	0,30	0,32	0,34	0,30	0,33	0,35	0,38	0,32	0,35	0,38	0,41	0,34	0,37	0,40	0,44	0,35	0,39	0,43	0,46
300 <sup>2)</sup>	t=	0,39	0,42	0,46	0,48	0,42	0,46	0,50	0,53	0,45	0,49	0,54	0,57	0,48	0,53	0,57	0,62	0,50	0,56	0,61	0,65
450 <sup>3)</sup>	t=	0,52	0,56	0,60	0,64	0,56	0,61	0,66	0,70	0,59	0,65	0,71	0,76	0,63	0,69	0,75	0,81	0,66	0,73	0,80	0,86
600 <sup>4)</sup>	t=	0,66	0,70	0,74	0,80	0,70	0,75	0,80	0,86	0,73	0,79	0,85	0,92	0,77	0,83	0,89	0,97	0,80	0,87	0,94	1,02

s [mm]	t [s]	$n_L = 28 ; n_T = 64$ A= 4200mm				$n_L = 32 ; n_T = 72$ A= 4800mm				$n_L = 36 ; n_T = 80$ A= 5400mm				$n_L = 40 ; n_T = 88$ A=6000mm				$n_L = 44 ; n_T = 96$ A=6600mm			
		m [kg]				m [kg]				m [kg]				m [kg]				m [kg]			
		0,5	1	1,5	2	0,5	1	1,5	2	0,5	1	1,5	2	0,5	1	1,5	2	0,5	1	1,5	2
150 <sup>1)</sup>	t=	0,37	0,41	0,45	0,49	0,39	0,43	0,47	0,51	0,40	0,45	0,50	0,54	0,42	0,47	0,52	0,56	0,43	0,49	0,54	0,58
300 <sup>2)</sup>	t=	0,52	0,58	0,64	0,69	0,55	0,61	0,67	0,73	0,57	0,64	0,70	0,76	0,59	0,66	0,73	0,79	0,61	0,69	0,76	0,82
450 <sup>3)</sup>	t=	0,69	0,77	0,84	0,91	0,72	0,81	0,88	0,96	0,75	0,84	0,92	1,00	0,78	0,87	0,96	1,04	0,81	0,91	1,00	1,09
600 <sup>4)</sup>	t=	0,86	0,96	1,04	1,13	0,89	1,00	1,08	1,18	0,92	1,03	1,12	1,22	0,95	1,06	1,16	1,26	0,98	1,10	1,20	1,30

\*\* Other distances „A“, strokes or stroke times on request

s = Stroke [mm]  
t = Stroke Time [s]  
 $\alpha$  = Switching angle on the drive [°]

$n_L$  = Number of links in line  
 $n_T$  = Number of links total

m = Weight per link [kg]  
A = Distance between U-Turns

<sup>1)</sup> The chain moves one link with each index.

<sup>2)</sup> The chain moves two links with each index.

<sup>3)</sup> The chain moves three links with each index.

<sup>4)</sup> The chain moves four links with each index.

## Technical specifications

### Main dimensions

Distance** [mm]	in steps of 600
Weight at A=2000 [kg]	800
Stroke time** [s]	see Load Table
Stroke** [mm]	150, 300, 450 or 600
Direction	right, left

### Loadings

pro stehendem Kettenglied	
Kraft senkrecht [N]	1250
Kraft quer [N]	2600
Kippmoment [Nm]	120
Zugkraft an Kette [N]	6000

### Precision

in feed direction*	
at the drive [mm]	±0,04
opposite the drive [mm]	±0,07
Transverse to feed direction [mm]	±0,05
vertical runout [mm]	±0,03

### Standard Drive

RT250 with 12<sup>1</sup>, 6<sup>2</sup>, 4<sup>3</sup> or 2 Indexes

\* for the first and the last link in line we can not guarantee this precision.

# Inquiry and order form for TAKTOMAT conveyor LFA (1)

Firm \_\_\_\_\_ E-Mail adress \_\_\_\_\_

Contact person \_\_\_\_\_ Project / Order no. \_\_\_\_\_

Tel. / Fax \_\_\_\_\_ Date \_\_\_\_\_

## Type

- LFA080
- LFA100
- LFA125
- LFA150
- other type \_\_\_\_\_

Distance A [mm] \_\_\_\_\_

Number of links in line  $n_l$  \_\_\_\_\_

Stroke (0,5 x, 1 x, 2 x, 3 x or 4 x length of one link)  
\_\_\_\_\_

- vertical assembly (use only the links on top)
- horizontal assembly (the links on both sides can be used)

## Mode of motion

- Stop mode (fixed index time, variable dwell time)  
index time \_\_\_\_\_
- Continuous mode (fixed index and dwell time)  
Number of cycles per minute \_\_\_\_\_  
Ratio index time : dwell time (or angle) \_\_\_\_\_
- Flexible (with torque or servo motor)

## Payload

Weight of a fixture \_\_\_\_\_

Weight of a workpiece \_\_\_\_\_

Distance from center point of mass of payload to surface of the link  
\_\_\_\_\_

vertical assembly

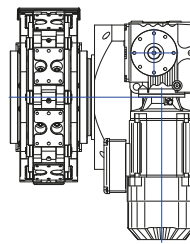

horizontal assembly

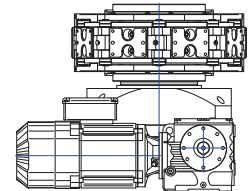

vertical assembly with protection

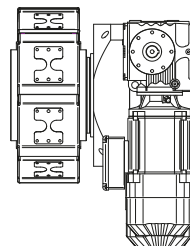

horizontal assembly with protection

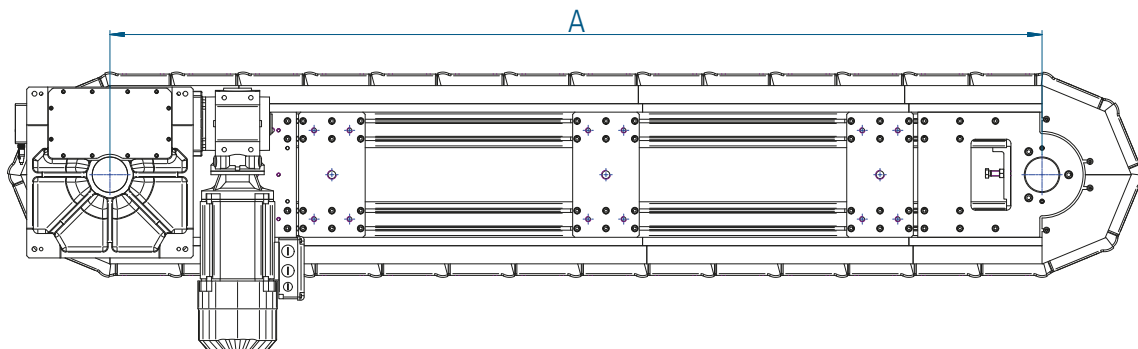
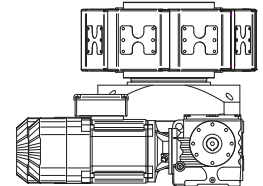

# Inquiry and order form for TAKTOMAT conveyor LFA (2)

## Possible mounting positions for the drive units

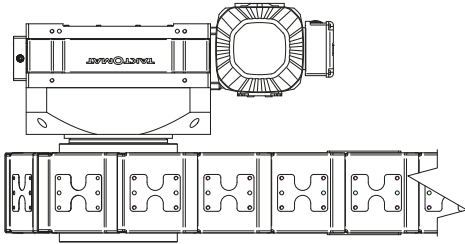

R (in pull direction on the right)

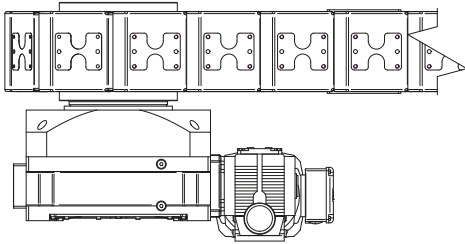

L (in pull direction on the left)

## Position of the free drive shaft

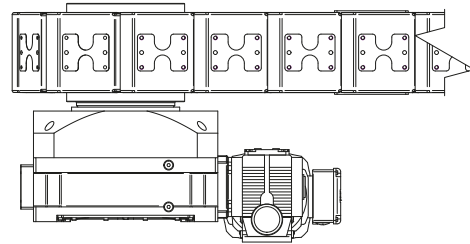

I (free drive shaft to the outside)

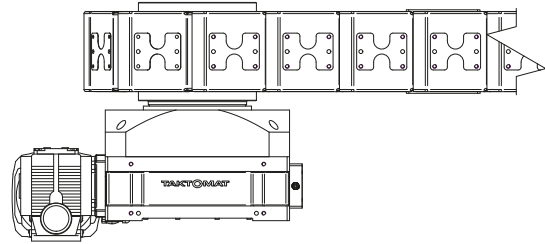

A (free drive shaft to the inside)

## Drive

With indexer type RTxxx

Mounting position of drive  L  R

Position of the free drive shaft  A  I (for vertical shaft)

Motor voltage  230/400V 50Hz

277/480V 60Hz

other \_\_\_\_\_

Brake Voltage

24V DC

230V AC

400V AC

other \_\_\_\_\_

with external drive (servomotor and gearbox or similar) \_\_\_\_\_

Torque

Without drive

## Accessories

### Color

Cast housing  RAL7016  other \_\_\_\_\_

Color of the drive  Fabricator color  other \_\_\_\_\_

Universal Controller TIC  yes  no

machined steel parts blued, aluminum parts nature

Protection cover  yes  no

# Accessories

## Universal Controller TIC



### Features and user benefits

An index table can be controlled in many different ways. We have developed this universal control to provide our customers with a user-friendly tool for operating the rotary table requiring minimal effort on the operator's part.

- Cycle time optimization through accurately stopping the drive in Dwell
- Minimizing installation and hardware expenses
- Easy integration through fieldbus connection (ProfiNet, EtherCAT, Ethernet / IP) and integration aids (step by step instructions and video tutorial)
- Motor protection switch and mechanical or electronic contactors can be eliminated. Only line protection necessary.
- Fast, gentle gear brakes with emergency stop
- Safety functions STO, SS1, SLS for max. PL e (SIL 3) at STO
- Soft restart or after emergency stop
- Machine gently jog also possible for large tables
- Oscillation or rotation reversal without additional hardware possible
- Simple change of speed possible
- No brake wear, the brake only closes after emergency stop
- Monitoring the engine temperature
- Compact, space-saving design

### Common applications

The universal control is the ideal solution for all three-phase motor-driven gears:

- Rotary indexers type RT and TT
- Rotary indexer TSR
- Globoidal index drives TG
- Parallel gears XT, TP and SP
- Linear transfer system type LFA



# TAKTOMAT

passion for automation

Rudolf-Diesel-Str. 14 D 86554 Pöttmes Tel +49 (0)82 53-99 65-0 Fax +49 (0)82 53-99 65-50  
info@taktomat.com www.taktomat.com

