

Step feeder SHB



- Low input height
- Extends the autonomy
- Gentle handling
- Compact design

Our step hopper fulfills the function of a storage hopper to extend the autonomy of the plant. Additionally, the filling material is gently transported upwards. This is achieved by using opposing pushers, which transport the parts upwards in several steps. Further transport is then carried out by your own or **LAS** feeding systems.

Advantages

- Ergonomics**
 - Low filling height
 - Ideal for manual filling
 - Low noise level
 - Fulfills the machine guideline 1.1.6.
- Protection of parts**
 - No vibration due to design
 - Low mechanical stress on the parts
 - Narrow gap dimension

Suitable for screws, nuts, pins, springs, clamps, coated parts, plastic parts and many more.

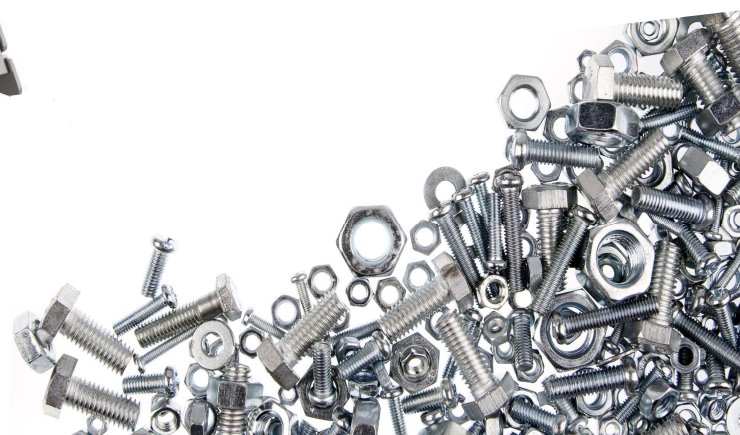

Technical data

| Type | SHB 15 | SHB 25 | SHB 35 |
|---------------------------------------|--------|--------|--------|
| Hopper volume in liter | 15 | 25 | 35 |
| Min. filling height in mm (A) approx. | 770 | 820 | 870 |
| Min. transfer height in mm (B)* | 1.100 | 1.100 | 1.100 |
| Max. filling weight in kg | 40 | 50 | 60 |
| Overall width in mm | 501 | 501 | 501 |
| Overall depth in mm | 1.156 | 1.156 | 1.156 |
| Step width in mm | 210 | 210 | 210 |
| Step depth in mm | 20 | 20 | 20 |

*The transfer height depends on the filling height

- Filling height and overall height depend on the transfer height and the hopper volume
- The filling chute respectively the hopper area have an angle of inclination of min. 30°
- Further versions with regard to filling and transfer heights are available
- Standard version with adjustable feet (adjustable +/- 50 mm)
- Compressed air requirement min. 5-6 bar (cleaned, dry, oil-free)
- Subject to technical modifications

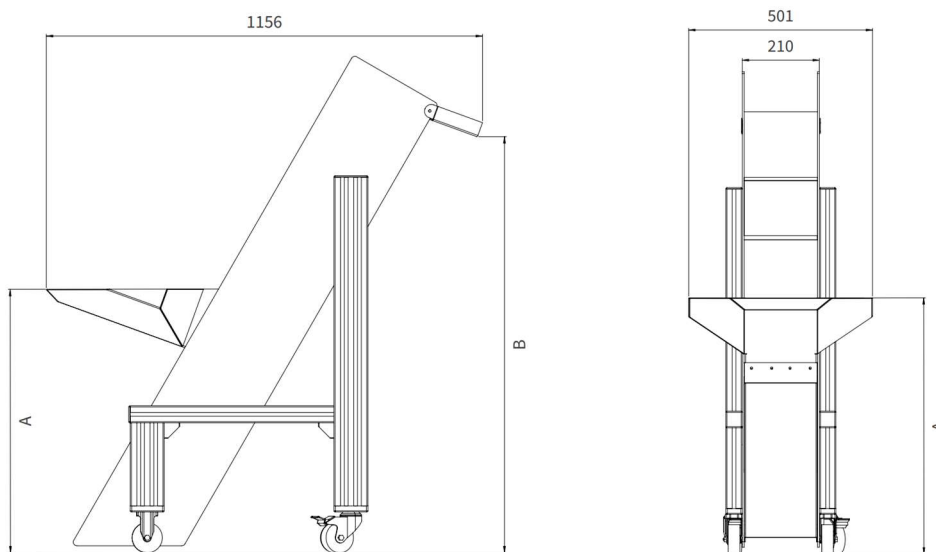

Options

- 4 Transport wheels
- Makrolon cover with flap
- Filling funnel that can be integrated into the cover of the customer's conveyor
- Various coatings
- Non-contact level detection
- LAS mini control system

Contact

LAS Lean Assembly Systems GmbH
 Talstr. 13
 D-73547 Lorch-Weitmars, Germany

Marco Hübl
 Tel. +49 (0) 7172 18917-610
 Mail m.huebl@las-automation.de